

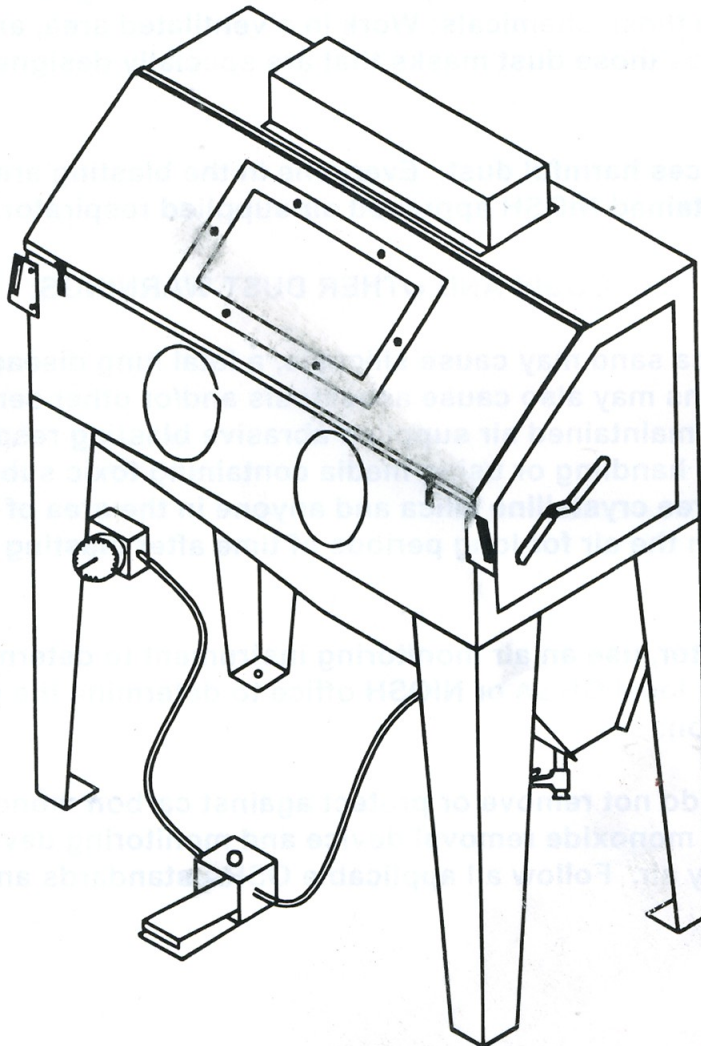

48" ABRASIVE BLAST CABINET

OPERATING AND MAINTENANCE INSTRUCTIONS



WARNING!

Do not use a Cabinet Blaster until you have read this manual and you understand its contents and warnings. These warnings are included for the health and safety of the operator and those in the immediate vicinity. Keep this manual for future reference.

Dust created by power sanding, sawing, grinding, drilling, and other construction activities may contain chemicals known to cause cancer, birth defects or other reproductive harm and respiratory illnesses. Some examples of the chemicals include:

- Lead from lead based paints
- Crystalline silica from bricks, cement and other masonry products
- Arsenic and chromium from chemically-treated lumber

Your risk from these exposures varies, depending on how often you do this type of work. To reduce your exposure to these chemicals: Work in a ventilated area, and work with approved safety equipment, such as those dust masks that are specially designed to filter out microscopic particles.

Abrasive blasting produces harmful dust. Everyone in the blasting area must wear a properly fitted and properly maintained NIOSH approved air supplied respirator.

SILICOSIS AND OTHER DUST WARNINGS:

Breathing dust from silica sand may cause silicosis, a fatal lung disease. Breathing dust during blasting operations may also cause asbestosis and/or other serious or fatal diseases. A NIOSH-approved, well maintained air supplied abrasive blasting respirator must be used by anyone blasting, anyone handling or using media containing toxic substances or media with more than point one percent (.001) free crystalline silica and anyone in the area of the dust. Harmful dust can remain suspended in the air for long periods of time after blasting has ceased, causing serious injury or death.

Before removing respirator, use an air monitoring instrument to determine if atmosphere is safe to breathe. Contact local OSHA or NIOSH office to determine the proper respirator for your particular application.

Air supplied respirators do not remove or protect against carbon monoxide (CO) or any other toxic gas. Use a carbon monoxide removal device and monitoring device with the respirator to ensure grade D quality air. Follow all applicable OSHA standards and OSHA regulation 1910.134 (d).

WARNING AND SAFETY INFORMATION

Do not operate cabinet or air flow with cabinet door open or with cabinet lens removed.

Do not use fluids or mix fluids with blast media.
This cabinet is designed for dry blasting only.

Do not exceed maximum operating pressure of 110 PSI.

WARNING!

Disconnecting hose while Unit is under pressure could cause serious injury or death. Use safety lock pins and safety cables in all coupling connections to help prevent hose couplings from accidental disconnection.

WARNING!

Failure to observe the following before performing any maintenance could cause serious injury or death from the sudden release of compressed air:

- Disconnect power supply.
- Lockout and tagout the compressed air supply.
- Bleed the air supply line to the blast gun.

Immediate replacement of worn components is required. Failure to replace worn components could expose the operator or bystanders to high speed media and compressed air could cause death or serious injury.

Leaks around couplings and nozzle holders indicate worn or loose fitting parts. Nozzle holders and couplings that do not fit tightly on hose and nozzles that do not fit tightly in nozzle holders could disconnect while under pressure. Impact from nozzles, couplings, hoses, or abrasive, and parts disconnected while under pressure could cause severe injury.

Do not use this equipment in any area that might be considered hazardous or where flammable gases or liquids are present. Failure to do so may cause an explosion resulting in serious injury.

AIR COMPRESSOR RECOMMENDATION:

To permit efficient operation of your air compressor, follow these guidelines:

1. Use a smaller size nozzle to control the demand of air.
2. Do not blast continuously. Stop blasting operation periodically to allow the compressor to cool. No compressor is designed to constantly run at full RPM. Use 70% of the rated output.
3. Use a minimum 1/2" air hose or metal piping from your air compressor to the blaster. If your compressor is creating an excessive amount of moisture, we recommend using a water trap or a moisture separator.
4. The air compressor should be drained at the bottom of the supply tank through a drain valve and should be blown down daily. It is not unusual to drain three or four gallons of water from the supply tank on a high humidity day. An additional supply tank will help.
5. Keep dust and media created by blasting away from the air compressor unit. Observe maximum air pressure requirements for the blaster and either set your compressor to run within these limits or use a pressure regulator valve to reduce the air pressure to the appropriate range.

ABRASIVE (MEDIA) USAGE:

1. If moisture is in the media it will eventually damage the blaster tank or plug the system. Keep the media and compressor air dry to avoid this problem.
2. If media is moist, screen it and dry it before using.
3. Do not leave media in the tank after blasting because it can absorb moisture and impair blasting performance.
4. Store media in a dry place; keep media off the ground or concrete floors. Put it on a wooden skid.
5. If the humidity is excessively high, it may not be advisable to blast at that time.
6. Consider using different grades or different types of media to prevent nozzle clogging due to high moisture content.
7. Do not use sand.

If twist-on type air hose couplings are used, they must be secured by safety lock pins or wires to prevent accidental disconnection while under pressure. Hose disconnection while under pressure could cause serious injury.

CABINET BLASTER SAFETY PROCEDURES

CAUTION: READ THESE SAFETY PROCEDURES IN THEIR ENTIRETY – PARTS OF THE OPERATING INSTRUCTIONS ARE WITHIN THESE WARNINGS.

These procedures are not intended to be exhaustive due to the many variables in the abrasive blasting field. Therefore, we INSIST that the hands, ears, mouth, nose and eyes be covered with appropriate safety protection at all times.

ADDITIONAL WARNINGS! CAUTION MUST BE EXERCISED BY USER AT ALL TIMES

1. Do not exceed maximum working pressure of 110 PSI. Failure to keep maximum working pressure below 110 PSI can cause the blast machine to burst, causing death or serious injury.
2. Everyone in the blast area including the equipment operator should correctly use and maintain a NIOSH approved air supplied respirator, even after blasting has ceased. Harmful dust can remain suspended in the air for long periods of time after blasting has ceased causing injury or death
3. For safe operation, perform recommended preventive maintenance on blaster cabinet, and accessories. Replace all worn parts before they fail. Immediate replacement of worn components is required. Failure to replace worn components could result in exposing the operator or bystanders to high speed media and compressed air, causing serious injury.
4. Do not use corrosive materials of any type in unit. Use only clean, dry media.
5. Static electricity can be created by the use of this equipment. Do not use within fifty feet of any explosive, potentially explosive substances, or their vapors as an explosion can occur.

IMPORTANT WARNING

Read all instructions before using this equipment. For efficient and safe production, reference OSHA requirements.

Remember:

1. Start up preparations:

- Supply air line should be sized according to the table shown on page 6. All hoses should be rated at least 125 PSI and an isolation valve should be installed so that supply air can be turned off and then disconnected from blast machine for servicing.
- Supply air should be dry and clean from oil and other contaminants. (I.e. use air dryer, coalescent filter, or moisture separator as needed.)
- Blast machine must be grounded to avoid shock.
- Electric extension cords should be three wire grounded, and rated for the amperage of the blaster. Check nameplate for rated amps.

2. Operator's responsibilities before starting:

- Inspect fittings and hoses for damage and wear.
- Check the seal on all doors. Only operate the blast cabinet with all doors securely closed and dust collection system running.
- Clean dust from dust collector and clean filter as needed.

3. Caution:

- Unless otherwise specified, working pressure of blast machine and related components must not exceed 110 PSI.
- Keep blast nozzle controlled and aimed at the work.

4. Maintenance

- Keep your machine in good repair. Use **ALLSOURCE** parts and do not substitute or modify **ALLSOURCE** supplied items.

IMPORTANT NOTICE

TO DISTRIBUTORS, PURCHASERS AND END USERS OF **ALLSOURCE** PRODUCTS

The information provided described and illustrated in this material is intended for experienced, knowledgeable users of abrasive blasting equipment and supplies (products).

The products described in this material may be combined as determined solely by the user in a variety of ways and purposes. However no representations are made as to intended use, performance standards, engineering suitability, safe practices or compliance with government regulations and laws that apply to these products, products of others, or a combination of various products chosen by the user or others. It is the responsibility of the users of these products, products of third parties, and a combination of various products, to exercise caution and familiarize themselves with all applicable laws, government regulations and safety requirements.

Nor are representations made or intended as to the useful life, maintenance cycles, efficiency or performance of the referenced products of any combination of products.

This material must not be used for estimating purposes. Production rates, labor performance or surface finishes are the sole responsibility of the user based on the users expertise, experience and knowledge of industry variables.

It is the responsibility of the user to insure that proper and comprehensive training of operators has been preformed and all environmental and safety precautions observed.

ALLSOURCE provides a variety of excellent products to the surface preparation industry, and we are confident that all proficient users, operators and contractors in this industry will continue to use our products in a safe and knowledgeable manner.

Before using this product, read all instructions, literature, labels, specifications and warnings sent with and affixed to the unit. If operation of the unit is unclear after reading this manual, contact your supervisor for instructions. It is the responsibility of the employer to read the following instructions to users of this equipment, who are unable to read. Periodic inspection at the work site should be made by supervisory personnel to ensure the blast machine is being properly used and maintained. A copy of this owner's manual must be kept with the blast machine and readily accessible to the blast machine operators at all times.

ASSEMBLY INSTRUCTIONS

1. Remove all parts from inside cabinet including floor grate from bottom of crate, underneath cardboard.
2. Remove all parts from inside cabinet.
3. Place cabinet on its top(#22).
4. Attach legs using four 1/4 x 1/2" bolts.
 - a) Front left leg has name plate.
 - b) Rear legs will also take 2 self tapping screws each.
5. Stand cabinet upright on legs.
6. Attach bracket with pressure gauge (#8) to left front leg with two 1/4 x 3/4" bolts, lock washers and nuts.

7. Place foot pedal between front legs.
8. Attach metering valve (#13) using three self-tapping screws to back bottom on cabinet. Snap closed with door catch.
9. Attach left and right doors (#6) with four nuts.
10. Loosen bolts on door catches (#20) and move out to full extent and tighten bolts. Moving them in slightly will tighten door seal.
11. Place glass (#19) on top of cabinet.
12. Place light fixture (#1) on glass with light switch on right side. Fasten to cabinet with four 1/4 x 3/4" bolts and flat washers.
13. Dust Collector
 - a) Attach body of dust collector to rear panel (right side) aligning pipe with hole. Use 1/4" x 3/4" bolts and flat washers.
 - b) Place top of dust collector (with motor and filter) into top of unit. Do up the 2 catches.
14. Tighten all bolts, nuts and screws.
15. Place floor grate with cut out corner to front right of cabinet. Bring hoses through opening.
16. Plug dust collector into female plug coming from light. Then plug male cord from light into 115Volt 60Hz supply. Turn on switch on vacuum, the switch on cabinet will turn on light and vacuum or dust collector.
17. Put media into cabinet through floor grate. (approx 15LBS)

OPERATING INSTRUCTIONS

1. Preparing parts for blasting

All parts processed must be free of oil, grease and moisture. Make sure parts are dry before putting into the cabinet for cleaning.

2. Air pressure

Operating Pressure: from 50 to 80 PSI. (pounds per square inch)(higher pressures up to 110 PSI can be used but this breaks down some types of media's prematurely).(ex. glass bead)

- Set air pressure to 80 PSI. Most parts for blast cleaning can be blasted at 80 PSI. For light gauge steel, Aluminum, and other more delicate parts, start at lower pressure and gradually increase the pressure until the desired finish is achieved.

WARNING:

DO NOT CONNECT TO HIGH PRESSURE BOTTLE GAS, RUPTURE AND EXPLOSION CAN OCCUR.

3. Gun angle and distance

Direct gun at parts at 45-60 degree angle with ricochet towards the back of the cabinet. Do not hold gun at 90 degree angle to parts being processed. This will cause the media blast to bounce back into the blast stream and slow blasting action. Also 90 degree angle will cause excessive wear on gun and viewing window. Hold gun approximately 6 inches from parts being blasted.

WARNING:

GUN MUST ALWAYS BE POINTED AWAY FROM THE OPERATOR AND TOWARDS ITEMS BEING PROCESSED. NEVER BLAST WITH ANY OF THE CABINET DOORS OPEN. WHILE LOADING AND UNLOADING, NO ONE SHOULD BE AT THE OPERATOR STATION, AT THE FRONT OF THE BLAST CABINET.

4. Media

- Media should be of good quality and dry. Moisture will cause the media not to flow and will clog metering valve and hopper.

NEVER USE SAND

There are many types and sizes of media for different finishes. If you are having a problem selecting a media for a specific job, contact your distributor for recommendations.

5. Metering Valve

- The metering valve adjusts the amount of media being pulled into the venturi gun. This valve, located at the bottom of the hopper, has the media stored on top of it. When air is sent to the gun from the foot pedal a vacuum is created that sucks air and media up into the gun through the clear media hose. A 7/16" bolt on the top of the metering valve can be adjusted to vary the amount of air that is sucked in through the holes. If the holes are too far closed, the mixture will have too much media and the gun will pulsate. If the holes are too far opened, too little media will go to the gun and production will decrease.

6. Nozzle Size

- By changing to the next larger size of nozzle, production can increase significantly. Larger sized nozzles produce a larger cleaning pattern. This, however, requires more air (your compressor must be able to provide this)

MAINTENANCE INSTRUCTIONS

1. Blasting Gun

- After 10-12 hours of blasting time, the nozzle should be checked. If it shows uneven wear it should be turned 1/4 turn every 10 hours of use.

2. Caking of media

- Media caking is caused by moisture in the air supply or from oily and greasy parts. If this is not corrected media will not flow evenly and will plug up in the metering valve and the gun. Check air supply: if water is present install a good moisture trap. If oily or greasy parts are being blasted, you should degrease and dry the parts first.

3. Reverse pressure

- If media stops flowing occasionally, cover nozzle (hold tight) and push foot pedal down for a couple of seconds. This will cause the system to back blast through the gun and up the media hose. This will help loosen any clogs.

4. Gun air pressure drop

- Set the air pressure to 80 PSI on the air gauge at regulator. Push the foot pedal while holding gun and see if the gauge pressure drops significantly. If the pressure drops, this indicates that there is a restriction in the supply line. This could be hose that is too small, a reducer or quick coupler, a plugged filter, or other piping that doesn't allow enough air through. Also if the cabinet is too far from the air compressor, a pressure drop will occur. Air supply line should be 1/2" or larger.

5. Poor visibility-Excessive dust:
 - Air inlet at front left above regulator, should be free to allow air into cabinet.
 - Dust container full and needs to be cleaned and emptied. (latch at bottom of dust collector or remove black cover on vacuum.
 - Dust cartridge contaminated. (clean or replace filter in dust collector, part #29)
 - Media breakdown; Eventually the media becomes so small that it is essentially dust. Replace media and clean dust collector.
6. Poor visibility-Viewing window

ALLSOURCE windows come with a clear plastic protector on them. As these become pitted they can be easily replaced to extend the life of the window. The window can also be easily replaced.
7. Poor media flow
 - Check for moisture as indicated above. Install moisture trap as needed, Replace damp media and clean hoses and sump.
 - Holes in media hose will cause poor media delivery. Replace hose.
 - Debris in media. Replace or screen media.

MAINTAIN SUCTION EFFICIENCY WITH SIMPLE STEPS

The most common problem customers have with their suction (venturi) blast cabinets is a decrease in production rates. A properly maintained suction cabinet should provide years of constant service. When production rates fall the operator can usually locate the problem by checking

1. Air supply
 - If the pressure gauge on the regulator shows an adequate no-load supply (when the blaster is not running), press the foot pedal. If the pressure drops more than a few PSI your air supply is restricted or inadequate. Clean filters and moisture separators all the way back to the air compressor. Straighten any kinked lines. Use a master gauge to check the air pressure or replace existing gauge if you suspect it is giving you false readings.
2. Blast gun
 - The nozzle will wear out eventually. Replace it if it measures 1/16" over its original size or if it shows uneven wear. Adjust as needed for different media and conditions. A properly working gun will pull 15-17 inches of mercury on a manometer.
3. Dust collector
 - Inadequate cabinet ventilation results in reduced cleaning power at the nozzle as well as diminished view of the work in progress. Use the dust collectors shaker every 20-30 minutes when the cabinet is turned off, (more often in dusty conditions. Empty dust collector at least once a day. Remove filter and blow out occasionally to keep the dust collector or vacuum working efficiently. Replace as needed.
4. Media
 - Use quality blast media sized to the job. Damp or dirty media can bring blasting to an instant halt. Store media in a dry area and load the appropriate quantity. Add enough media through the flooring to have 6" deep of media on top of the metering valve. If you run out of media as you are blasting add enough so it keeps circulating to the gun. The media will eventually break down or get too contaminated to use. The less there is in the system, the less you will have to replace.

MEDIA

Coal Slag

Coal Slag is used when paint and rust has to be removed from steel, such as car bodies, tanks or heavy machinery. Coal Slag is superior to silica because it only has .1% free silica, is faster cutting, can be re-used, is moisture free, and will not pack or absorb moisture. (25 Lb. container)

Steel Grit

Steel grit is extremely fast cutting on rusty metal and hard to remove paint. Steel Grit is popular because it leaves a very smooth finish. It is also comparable in price to most other specialty abrasives. Steel Grit is recommended in reclaim systems or cabinets. (25 Lb. container)

Glass Bead

Glass Bead is used in creating a satin or matte finish. Glass Bead is recommended in reclaim systems or cabinets. (25 Lb. container)

Aluminum Oxide

Aluminum Oxide is a high quality abrasive that is sharper than sand (not recommended) and cuts twice as fast as sand. It leaves a smooth textured finish with no pits or burrs. Aluminum Oxide is rougher than glass bead and can be used over and over again. It is one of the most economical abrasives you can use in any reclaim systems or cabinets. (4/25 Lb. container)

Plastic Grit

Primarily used to strip aluminum and fiberglass. Great for stripping paint, light oxidation and surface rust. Recommended for use in blast cabinets because it creates very little dust. Works quickly, last a long time and increases visibility within the cabinet. (10 Lb. container)

Walnut Shells

Walnut shells are recommended for use on "soft" surfaces such as aluminum, glass, wood, and other areas where no pitting is desired. Leaves a smooth, dull finish. (10 Lb. container)

5. Media delivery

- Replace any media hose that has soft spots or visible wear. Adjust the metering valve to provide adequate flow. A mixture that is too rich will cause plusating at the gun. An unusually loud noise while blasting means the mixture is too lean. A rich mixture can result in lower impact velocities, while a lean mixture reduces the number of impacts. Both reduce your cleaning rate. If everything is adjusted right and you are still not getting the production levels needed, contact your distributor. The suction system may be operating properly, it may be time to get a cabinet with a media reclaimed or a pressure system. Many upgrades are available.

AIR REQUIREMENTS

SUPPLY AIR PIPE SIZE in inches

| Line Length | Volume of air through pipe (cfm) | | | | | | | | | |
|----------------|----------------------------------|-----|-----|-----|----|------|------|------|------|------|
| | 25 | 30 | 35 | 40 | 50 | 60 | 70 | 80 | 100 | 125 |
| 25' | .75 | .75 | .75 | .75 | 1 | 1 | 1 | 1.25 | 1.25 | 1.25 |
| 50' | .75 | .75 | .75 | 1 | 1 | 1 | 1 | 1.25 | 1.25 | 1.25 |
| 75' | .75 | .75 | 1 | 1 | 1 | 1 | 1 | 1.25 | 1.25 | 1.25 |
| 100' | .75 | .75 | 1 | 1 | 1 | 1 | 1.25 | 1.25 | 1.25 | 1.25 |
| 150' | .75 | 1 | 1 | 1 | 1 | 1.25 | 1.25 | 1.5 | 1.5 | 1.5 |
| 200' | 1 | 1 | 1 | 1 | 1 | 1.25 | 1.25 | 1.5 | 1.5 | 1.5 |
| 250' | 1 | 1 | 1 | 1 | 1 | 1.25 | 1.25 | 1.5 | 1.5 | 1.5 |
| 300' | 1 | 1 | 1 | 1 | 1 | 1.25 | 1.25 | 1.5 | 1.5 | 1.5 |

Parts Listing for 41500 Cabinet

| ITEM # | PART # | DESCRIPTION | ITEM # | PART # | DESCRIPTION |
|--------|---------|------------------------------|--------|---------|---------------------------|
| 1 | 4150001 | Lamp Housing | 21 | 4150021 | Lid, cabinet |
| 1A | 4150041 | Switch | 22 | 4150022 | Cabinet |
| 2 | 4150002 | Lamp Fixture, 2 Bulbs | 23 | 4150023 | Legs, Cabinet |
| 3 | 4150003 | Lamp | 24 | 4150024 | Top of D.C. |
| 4 | 4150004 | Lamp Window | 25 | 4150025 | Vacuum Motor |
| 5 | 4150005 | Trim-Lock Window Seal, PE | 26 | 4150026 | Screws |
| 6 | 4150006 | Side Door | 27 | 4150027 | Cover Motor |
| 7 | 4150007 | Door Latch | 28 | 4150028 | Power Cord |
| 8 | 4150008 | Pressure Gauge, 1/4", 150psi | 29 | 4150029 | Dust Filter |
| 9 | 4150009 | Regulator, Air 3/8" | 30 | 4150030 | Round Dust Collector |
| 10 | 4150010 | Hose, Air Push on 1/2" | 31 | 4150031 | Sealing tape |
| 11 | 4150011 | 3/8" Foot Pedal Complete | 32 | 4150032 | Board, Exhaust |
| 12 | 4150012 | Metering Valve Plug | 33 | 4150033 | Push rod |
| 13 | 4150013 | Metering Valve | 34 | 4150034 | Cap, round dust collector |
| 14 | 4150014 | Clamp, Gloves | 35 | 4150035 | Side door-post |
| 15 | 4150015 | Gloves, pair | 36 | 4150036 | Hole |
| 16 | 4150016 | Windows Frame Cover | 37 | 4150037 | Cover |
| 17 | 4150017 | Glass | 38 | 4150038 | Bolt |
| 18 | 4150018 | Protection Film, PE | 39 | 4150039 | Web |
| 19 | 4150019 | Plastic board | 40 | 4150040 | Rubber strip |
| 20 | 4150020 | Mounting ring, Gloves | | | |

Parts Listing for 41500 Gun - 4150059

| ITEM # | PART # | DESCRIPTION |
|--------|--------------------|--------------------------------|
| 1 | 4150042 | Nozzle Holding Nut, Brass |
| 2 | 4150043 | Ceramic Nozzle set |
| | 4150044 | Ceramic Nozzle, 4mm |
| | 4150045 | Ceramic Nozzle, 5mm |
| | 4150046 | Ceramic Nozzle, 6mm |
| | 4150047 | Ceramic Nozzle, 7mm |
| 3 | 4150048 | O-ring, Nozzle |
| 4 | 4150049 | Gun Body, Mod-U-Blast(Only) |
| 5 | 4150050 | Air Jet Hex Nut, Brass |
| 6 | 4150051 | Sleeve, Air Jet |
| 7 | 4150052 | Air Jet |
| 8 | 4150053 | Swivel Air Inlet Fitting, 3/8" |
| 9 | 4150054 | Media Inlet Fitting, Barb 3/8" |
| 10 | 4150055 | Hose, Media 1/2" |
| 11 | 4150056 | Hose, Air 1/2" |
| 12 | 4150057 | Seal |
| 13 | 4150058 | Ring |

PARTS DIAGRAM

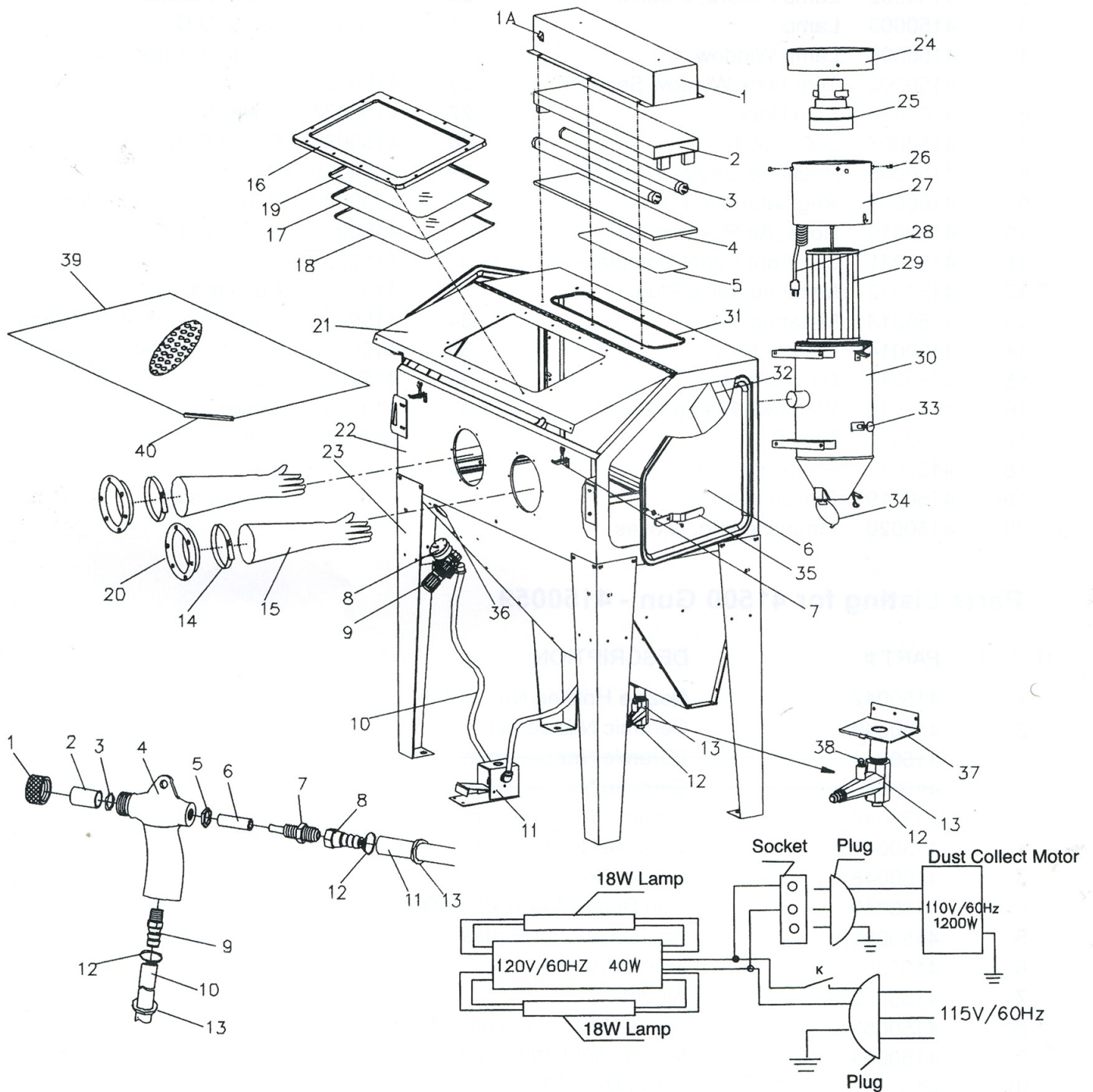

Disclaimer of Warranties. Manufacturer, distributor, and seller ("Seller") makes no warranties with respect to any goods delivered to Buyer or users except as specifically set forth within this manual. Seller MAKES NO IMPLIED WARRANTIES OF MERCHANTABILITY OR FITNESS FOR A PARTICULAR PURPOSE WITH RESPECT TO ANY OF THE GOODS, AND Seller EXPRESSLY DISCLAIMS ANY IMPLIED WARRANTIES AGAINST INFRINGEMENT. Seller WARRANTIES SHALL NOT APPLY TO ANY DAMAGE OR NON-CONFORMITY RESULTING FROM THE NEGLIGENCE OF IMPROPER ASSEMBLY OR USE OF ANY GOODS BY USERS OR BUYER OR ITS EMPLOYEES OR AGENTS, OR FROM ALTERATION OR ATTEMPTED REPAIR BY ANY PERSON OTHER THAN MANUFACTURER. ALL USED, REPAIRED, MODIFIED OR ALTERED ITEMS ARE PURCHASED AS-IS AND WITH ALL FAULTS.

LIMITED WARRANTY

Seller warrants this product to be free from defects in materials or workmanship for one year after the date of original purchase. This warranty does not include damage resulting from accident, abuse or misuse of the product. Nor does it apply to parts subject to abrasive wear, i.e., nozzles, valves, hose connections and hoses. Implied warranties including those of merchantability and fitness for a particular purpose are excluded to the extent permitted by law, and any and all implied warranties are excluded. Reimbursement of original purchase price is the exclusive remedy and liability for consequential damages under any and all warranties which are also excluded to the extent exclusion is permitted by law.

Disclaimer of Warranties: Manufacturer, Seller, and Seller's Agent (including
warranties with respect to any goods delivered to Buyer or others except as specifically
set forth within this manual - Seller, MAKER, NO IMPLIED WARRANTIES OF
MERCHANTABILITY OR FITNESS FOR A PARTICULAR PURPOSE WITH RESPECT
TO ANY OF THE GOODS, AND SELLER EXPRESSLY DISCLAIMS ANY IMPLIED
WARRANTIES AGAINST INFRINGEMENT, SELLER WARRANTS THAT SHELL NOT APPLY
TO ANY DAMAGE OR NON-COMFORMITY RESULTING FROM THE NEGLIGENCE OF
IMPORTER, ASSEMBLY OR USE OF ANY GOODS BY USERS OR BUYER OR ITS
EMPLOYEES OR AGENTS, OR FROM ALTERATION OR ATTEMPTED REPAIR BY
ANY PERSON OTHER THAN MANUFACTURER, ALL USED, REPAIRED, MODIFIED
OR ALTERED ITEMS ARE PURCHASED AS IS WITH ALL FAULTS

LIMITED WARRANTY

Seller warrants this product to be free from defects in materials or workmanship
for one year after the date of original purchase. This warranty does not include
damage resulting from accident, abuse or misuse of the product. Nor does it apply
to parts subject to excessive wear, i.e., valves, valves, hose connections and hoses.
Implied warranties including those of merchantability and fitness for a particular
purpose are excluded to the extent permitted by law. Remedies under this
warranty are excluded. Reimbursement of out-of-pocket expenses plus the exclusive
remedy and liability for consequential damages under any and all warranties which
are also excluded to the extent exclusion is permitted by law.

S & H INDUSTRIES
5200 RICHMOND ROAD
CLEVELAND, OHIO 44146
Telephone : 216-831-0550,
1-800-253-9726

