

ALC

40389
30" x 20" POLYMER BENCH TOP
CABINET

ASSEMBLY INSTRUCTIONS



ALC

DIVISION OF S&H INDUSTRIES
5200 Richmond Road • Cleveland, OH 44146
Phone 216-831-0550 • Toll Free 800-253-9726 •
Fax 216-831-9573
www.shindustries.com
E-mail: www.service@shindustries.com
Revised 1/5/07

WARNING!

Do not use an ALC Cabinet Blaster until you have read this manual and you understand its contents and warnings. These warnings are included for the health and safety of the operator and those in the immediate vicinity. Keep this manual for future reference.

Dust created by power sanding, sawing, grinding, drilling, and other construction activities may contain chemicals known to cause cancer, birth defects or other reproductive harm and respiratory illnesses. Some examples of the chemicals include:

- Lead from lead based paints
- Crystalline silica from bricks, cement and other masonry products
- Arsenic and chromium from chemically-treated lumber

Your risk from these exposures varies, depending on how often you do this type of work. To reduce your exposure to these chemicals: Work in a ventilated area, and work with approved safety equipment, such as those dust masks that are specially designed to filter out microscopic particles.

Abrasive blasting produces harmful dust. Everyone in the blasting area must wear a properly fitted and properly maintained NIOSH approved air supplied respirator.

SILICOSIS AND OTHER DUST WARNINGS:

Breathing dust from silica sand may cause silicosis, a fatal lung disease. Breathing dust during blasting operations may also cause asbestosis and/or other serious or fatal diseases. A NIOSH-approved, well maintained air supplied abrasive blasting respirator must be used by anyone blasting, anyone handling or using media containing toxic substances or media with more than point one percent (.001) free crystalline silica and anyone in the area of the dust. Harmful dust can remain suspended in the air for long periods of time after blasting has ceased, causing serious injury or death.

Before removing respirator, use an air monitoring instrument to determine if atmosphere is safe to breathe. Contact local OSHA or NIOSH office to determine the proper respirator for your particular application.

Air supplied respirators do not remove or protect against carbon monoxide (CO) or any other toxic gas. Use a carbon monoxide removal device and monitoring device with the respirator to ensure grade D quality air. Follow all applicable OSHA standards and OSHA regulation 1910.134 (d).

POLYMER BENCHTOP CABINET – 40389

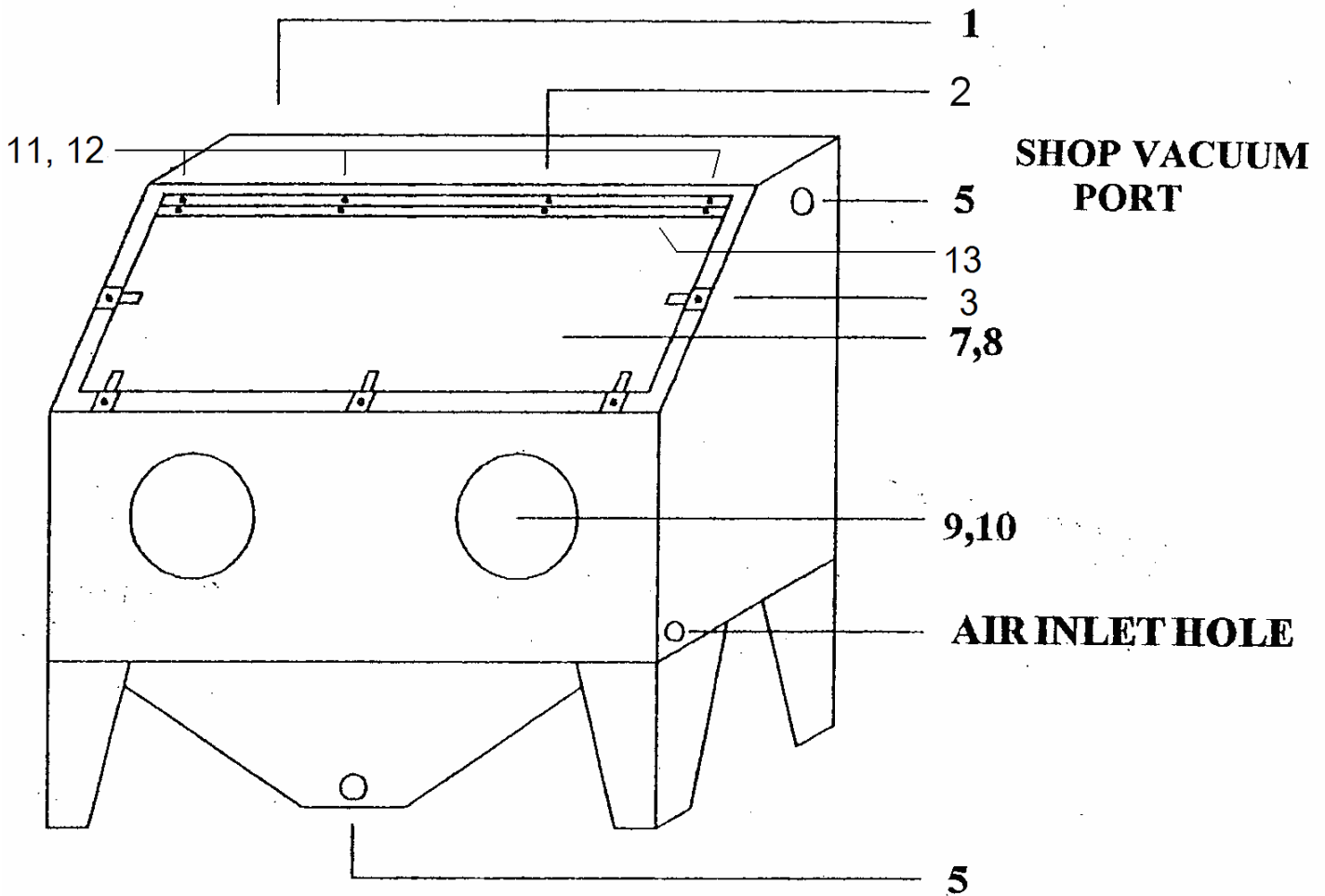

Key	Part No.	Description	Qty.	Key	Part No.	Description	Qty.
1	11646	Louver vent	1	8	11645	Lens underlay	1
2	11649	Hinge	1	9	11640	Rubber gloves – pair	1
3	11160	8-32 x 1/2" Screw	5	10	40240	Glove clamps	2
4	11161	8-32 Nut	13	11	10169	Small Screws Top	4
5	10904	Plug	2	12	10175	Small Screws Bottom	4
6	11644	Snap fastener	5				
7	11643	Lens	1				
ADDITIONAL PARTS NOT SHOWN ON SCHEMATIC							
	11208	Grate					
	40343	Pick-up tube					
	11605	Suction hose					

POLYMER BENCHTOP CABINET SIPHON GUN REPLACEMENTS PARTS

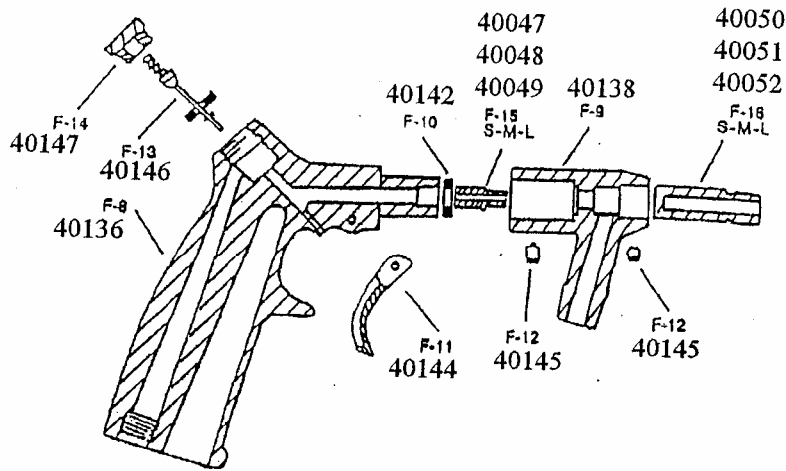

Part No.	Description	Part No.	Description
11604	Sandblast gun (economy)	40153**	Sandblast gun (USA) 5lb
40050**	Small nozzle, 7 CFM	40136**	Gun handle 5lb
40051	Medium nozzle, 15 CFM	40138**	Siphon head 5lb
40052**	Large nozzle, 20 CFM	40146**	Valve, spring, seat assembly 5lb
40047**	Small air jet, 7 CFM	40147**	Valve nut 5lb
40048	Medium air jet, 15 CFM	40144**	Trigger with pin 5lb
40049**	Large air jet, 20 CFM	40145**	Set screw 5lb
Nozzles and air jets are the only replacement parts available for economy sandblast gun		40142**	Air jet washer 5lb
	** = optional, not included		

ASSEMBLY INSTRUCTIONS

1. Take gloves and slip over circular flanges inside the cabinet. Secure gloves to flanges with glove clamps. If cabinet is supplied with 18" rubber gloves, help may be required to stretch gloves over the flanges. This is normal.
2. Attach abrasive blast hose to pick-up tube on inner portion of pick-up tube leaving 1/4" gap between hose end and outer tube. Lay pick-up tube in bottom of cabinet with hose end towards right rear of cabinet. Attach other end of hose to suction head of gun.
3. Attach pressure inlet hose (not supplied) to 1/4" threaded inlet on gun. If using whip hose inside cabinet, run threaded end through 9/16" diameter hole on lower right side of cabinet and attach quick disconnect nipple to hose end and tighten. If using shop hose directly through inlet hole to gun, the hole may need to be opened to accommodate hose diameter.

WARNING!

Disconnecting hose while Unit is under pressure could cause serious injury or death. Use safety lock pins and safety cables in all coupling connections to help prevent hose couplings from accidental disconnection.

If twist-on type air hose couplings are used, they must be secured by safety lock pins or wires to prevent accidental disconnection while under pressure. Hose disconnection while under pressure could cause serious injury

OPERATING INSTRUCTIONS

1. Maximum operating pressure is 110 PSI. Air consumption with medium nozzle supplied with cabinet is 15 CFM at 80 PSI.
2. To change abrasive, remove plug at bottom front of cabinet and drain into suitable container. Reinstall plug and pour new abrasive into cabinet.

3. The plug in the right upper side of cabinet is for installation of a shop vac. We strongly recommend the use of a ohasis or cabinet will leak the blast dust.
4. The 3" hole with louver vent in the upper left rear of the cabinet provides for proper venting of the cabinet during use. Never plug.

AIR COMPRESSOR RECOMMENDATION:

To permit efficient operation of your air compressor, follow these guidelines:

1. Use a smaller size nozzle and air jet to control the demand of air.
2. Do not blast continuously. Stop blasting operation periodically to allow the compressor to cool. No compressor is designed to constantly run at full RPM. Use 70% of the rated output.
3. Use a minimum 1/2" air hose or metal piping from your air compressor to the blaster. If your compressor is creating an excessive amount of moisture, we recommend using a water trap or a moisture separator.
4. The air compressor should be drained at the bottom of the supply tank through a drain valve and should be blown down daily. It is not unusual to drain three or four gallons of water from the supply tank on a high humidity day. An additional supply tank will help.
5. Keep dust and media created by blasting away from the air compressor unit. Observe maximum air pressure requirements for the blaster and either set your compressor to run within these limits or use a pressure regulator valve to reduce the air pressure to the appropriate range.

ABRASIVE (MEDIA) USAGE:

1. If moisture is in the media it will eventually damage the blaster tank or plug the system. Keep the media and compressor air dry to avoid this problem.
2. If media is moist, screen it and dry it before using.
3. Do not leave media in the tank after blasting because it can absorb moisture and impair blasting performance.
4. Store media in a dry place; keep media off the ground or concrete floors. Put it on a wooden skid.
5. If the humidity is excessively high, it may not be advisable to blast at that time.

6. Consider using different grades or different types of media to prevent nozzle clogging due to high moisture content.
7. Do not use sand.

CABINET BLASTER SAFETY PROCEDURES

CAUTION: READ THESE SAFETY PROCEDURES IN THEIR ENTIRETY – PARTS OF THE OPERATING INSTRUCTIONS ARE WITHIN THESE WARNINGS.

These procedures are not intended to be exhaustive due to the many variables in the abrasive blasting field. Therefore, we **INSIST** that the hands, ears, mouth, nose and eyes be covered with appropriate safety protection at all times.

ADDITIONAL WARNINGS! CAUTION MUST BE EXERCISED BY USER AT ALL TIMES

1. **Do not exceed maximum working pressure of 110 PSI. Failure to keep maximum working pressure below 110 PSI can cause the blast machine to burst, causing death or serious injury.**
2. **Everyone in the blast area including the equipment operator should correctly use and maintain a NIOSH approved air supplied respirator, even after blasting has ceased. Harmful dust can remain suspended in the air for long periods of time after blasting has ceased causing injury or death**
3. **Before using the pressure blaster: Put on safety glasses, gloves, and NIOSH-approved respirator. Always wear these protective items when operating and while servicing your abrasive blaster. A well maintained air supplied blasting respirator must be used by anyone blasting.**
4. **For safe operation, perform recommended preventive maintenance on blaster cabinet, and accessories. Replace all worn parts before they fail. Immediate replacement of worn components is required. Failure to replace worn components could result in exposing the operator or bystanders to high speed media and compressed air, causing serious injury.**
5. **Do not use corrosive materials of any type in unit. Use only clean, dry media.**
6. **Static electricity can be created by the use of this equipment. Do not use within fifty feet of any explosive, potentially explosive substances, or their vapors as an explosion can occur.**

7. Do not use this equipment in any area that might be considered hazardous or where flammable gases or liquids are present. Failure to do so may cause an explosion resulting in serious injury.

WARNING!

The threads on the nozzle holder must be inspected each time the nozzle is secured to the holder. Check the threads for wear, and make sure nozzle holder securely grips the nozzle. The nozzle washer must also be inspected for wear. Worn nozzle washers cause thread erosion. A loose-fitting nozzle may eject from the holder under pressure and could cause severe injury.

**MOUNTING INSTRUCTIONS FOR
THE OPTIONAL ECONOMY LIGHT KIT (P/N 40338)**

1. Using drill dimension sheet, drill 1.467 (1-7/16) hole in left side of cabinet. Drill (2) 0.187 (3/16) holes 1.625 (1-5/8) from center of large hole, one above and one below.
2. Unscrew ceramic lamp holder and install base through hole from outside and attach gasket and socket from inside.
3. Attach electrical box to outside of cabinet using 8-32 x 1/2" machine screws and nut. **NOTE:** Attach ground wire (green) to one of the screws that holds the box to the cabinet.
4. Attach neutral wire (white) from power cord to silver screw on socket base.
5. Attach black wire from socket base to one of the screws on the side of the switch.
6. Attach black lead from power cord to the other screw on the side of the switch.
7. Attach switch to box and install cover.
8. Install light bulb (not included) maximum 60 watt.

WARNING

Follow all electrical and safety codes as well as the National Electrical Code (NEC) and OSHA Regulations.

Light Kit Components	
Part No.	Description
11641	Lampholder
11642	Electrical box
11008	Power Cord
11009	Switch
11011	Box Cover
11160	8-32 x 1/2" Machine Screw (4)
11161	8-32 Nut (4)

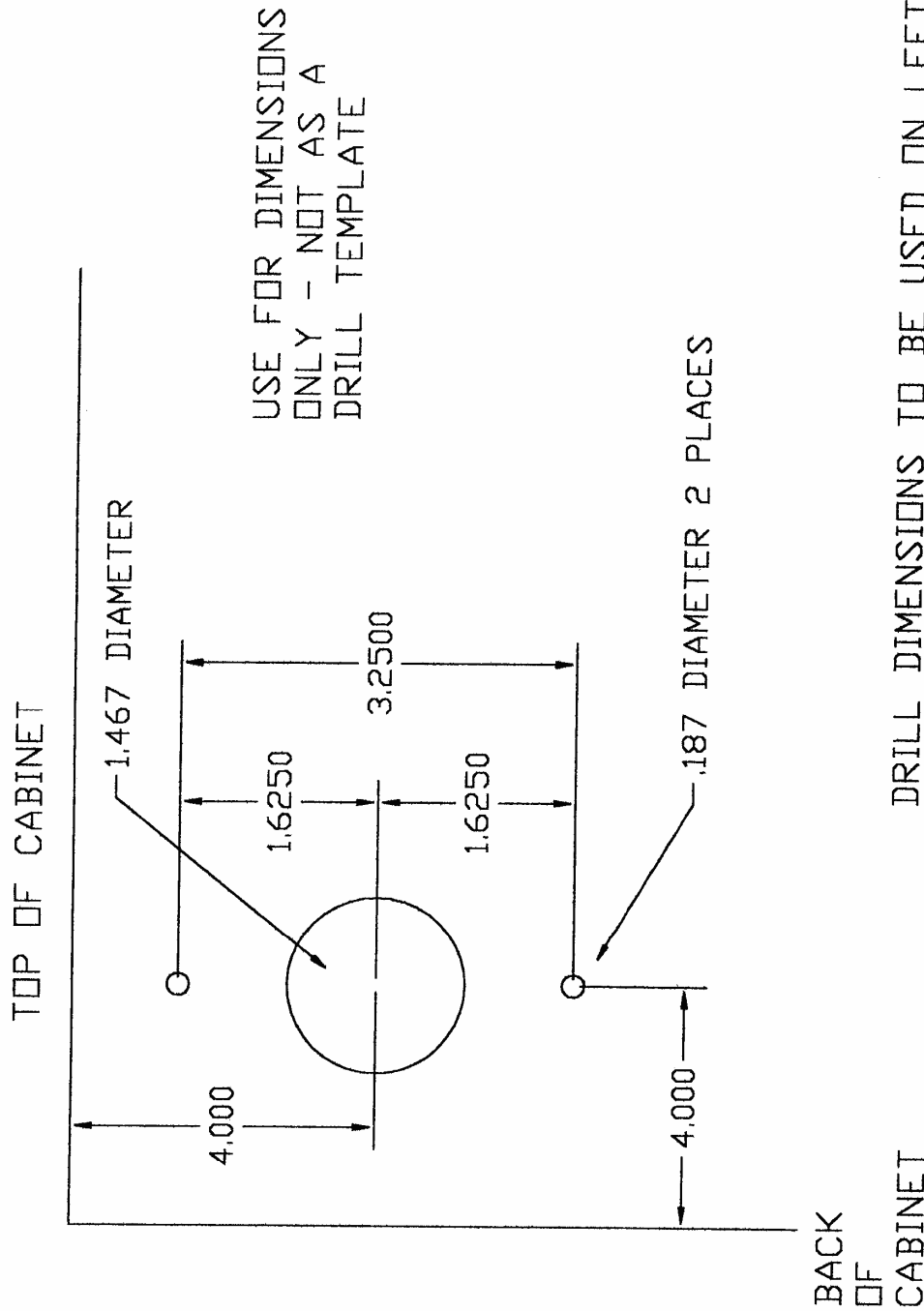

USE FOR DIMENSIONS
ONLY - NOT AS A
DRILL TEMPLATE

DRILL DIMENSIONS TO BE USED ON LEFT
SIDE OF CABINET FOR INSTALLATION OF
ECONOMY LIGHT KIT P/N 40338

MAINTENANCE**WARNING!**

Failure to observe the following before performing any maintenance could cause serious injury or death from the sudden release of compressed air:

- Disconnect power supply.
- Lockout and tagout the compressed air supply.
- Bleed the air supply line to the blast gun.

Immediate replacement of worn components is required. Failure to replace worn components could expose the operator or bystanders to high speed media and compressed air could cause death or serious injury.

Leaks around couplings and nozzle holders indicate worn or loose fitting parts. Nozzle holders and couplings that do not fit tightly on hose and nozzles that do not fit tightly in nozzle holders could disconnect while under pressure. Impact from nozzles, couplings, hoses, or abrasive, and parts disconnected while under pressure could cause severe injury.

Coal Slag #40093

Coal Slag is used when paint and rust has to be removed from steel, such as car bodies, tanks or heavy machinery. Coal Slag .1% free silica, is faster cutting, can be re-used, is moisture free, and will not pack or absorb moisture. (25 Lb. container)

Steel Grit #40109

Steel grit is extremely fast cutting on rusty metal and hard to remove paint. Steel Grit is popular because it leaves a very smooth finish. It is also comparable in price to most other specialty abrasives. Steel Grit is recommended in reclaim systems or cabinets. (25 Lb. container)

Glass Bead #40105

Glass Bead is used in creating a satin or matte finish. Glass Bead is recommended in reclaim systems or cabinets. (25 Lb. container)

Aluminum Oxide #40098

Aluminum Oxide is a high quality abrasive that is sharper than sand (not recommended) and cuts twice as fast as sand. It leaves a smooth textured finish with no pits or burrs. Aluminum Oxide is rougher than glass bead and can be used over and over again. It is one of the most economical abrasives you can use in any reclaim systems or cabinets. (4/25 Lb. container)

Plastic Grit #40110

Primarily used to strip aluminum and fiberglass. Great for stripping paint, light oxidation and surface rust. Recommended for use in blast cabinets because it creates very little dust. Works quickly, last a long time and increases visibility within the cabinet. (10 Lb. container)

Walnut Shells #40112

Walnut shells are recommended for use on "soft" surfaces such as aluminum, glass, wood, and other areas where no pitting is desired. Leaves a smooth, dull finish. (10 Lb. container)

TROUBLESHOOTING TIPS

PROBLEM/CAUSE

POSSIBLE SOLUTION

Surging of blast flow:

Air pressure too low

Check pressure gauge on air compressor

Excessive media consumption:

Air pressure too low

Check pressure gauge on air compressor

Clogging and plugging of blast flow:

Debris in media

Media size too large

Nozzle plugs

Wet media

Purge and screen

Use smaller grit size

Use larger nozzle and correct

Dry media, drain water from air

Moisture in abrasive media:

Wet media

Water in air

Change or use dry media

Drain water from air lines

Humid weather:

Moderate humidity

Moderate humidity

High humidity

Keep media as dry as possible

Use drier or moisture separator

Avoid that period of use if possible

Overtaxed Compressor:

Compressor too small

Nozzle size too large

Too many leaks in plumbing

Holes in abrasive hose

Air filter on compressor plugged

Restrict time used

Use smaller size

Seal and tighten plumbing

Replace hose

Clean or replace filter

Lack of air pressure:

Compressor too small

Supply valves not on full position

Nozzle size too large

Leaks in plumbing

Holes in abrasive hose

Air filter on compressor plugged

Use smaller nozzle

Open valves

Use smaller size

Seal and tighten plumbing

Replace hose

Clean or replace filter

Lack of abrasive flow:

Blaster empty

Moisture in media

Not enough air pressure

Abrasive hose kinked

Debris in media

Fill cabinet

Dry media

Check system

Straighten hose

Clean or screen media

Disclaimer of Warranties. S & H Industries, Inc. ("Seller") makes no warranties with respect to any goods delivered to Buyer or users except as specifically set forth within this manual. S & H INDUSTRIES, INC. MAKES NO IMPLIED WARRANTIES OF MERCHANTABILITY OR FITNESS FOR A PARTICULAR PURPOSE WITH RESPECT TO ANY OF THE GOODS, AND S & H INDUSTRIES, INC. EXPRESSLY DISCLAIMS ANY IMPLIED WARRANTIES AGAINST INFRINGEMENT. S & H INDUSTRIES, INC. WARRANTIES SHALL NOT APPLY TO ANY DAMAGE OR NON-CONFORMITY RESULTING FROM THE NEGLIGENCE OF IMPROPER ASSEMBLY OR USE OF ANY GOODS BY USERS OR BUYER OR ITS EMPLOYEES OR AGENTS, OR FROM ALTERATION OR ATTEMPTED REPAIR BY ANY PERSON OTHER THAN S & H INDUSTRIES, INC. ALL USED, REPAIRED, MODIFIED OR ALTERED ITEMS ARE PURCHASED AS-IS AND WITH ALL FAULTS.

Indemnification Agreement. Buyer agrees, to the fullest extent permitted by the law, to fully indemnify, hold harmless, and defend Seller, its parent, subsidiary, and affiliated companies, its owners, officers, directors, employees, agents, representatives and insurers (collectively, "Indemnities") from and against any and all claims, demands, suits, damages, judgments of sums of money, losses and expenses, including but limited to attorney's fees and costs (collectively "referred to herein as "Claims") arising out of or resulting from any bodily injury, sickness, disease or death or injury to or destruction of tangible property, arising out of or resulting from the use, sale or distribution of any and all products purchased from Seller by Buyer, regardless of whether or not such claim arises in whole or in part out of Seller's alleged fault, including but not limited to Seller's negligence, strict liability, products liability, breach of warranty or any other act or omission. Buyer expressly waives any and all immunity from suit by Seller, its parent, subsidiary, and affiliated companies, and its owners, officers, directors, employees, agents, representatives and insurers, by operation of any workers' compensation law or statute. **By purchasing from S & H Industries, Inc., Buyer acknowledges and represents that Buyer has read, fully understands and agrees to the Indemnification provisions set forth above.**

LIMITED WARRANTY

S & H Industries Inc. (SHI) warrants this product to be free from defects in materials or workmanship for two years after the date of original purchase.

If the product should become defective within that warranty period, SHI will repair or replace it (at SHI'S option) free of charge including return transportation to Buyer provided Buyer delivers it prepaid to S & H Industries Inc., 5200 Richmond Road, Bedford Hts., Ohio 44146.

This warranty does not include damage resulting from accident, abuse or misuse of the product. Nor does it apply to parts subject to abrasive wear, i.e., nozzles, air jets, seal blocks, valves, hose connections and hoses.

Implied warranties including those of merchantability and fitness for a particular purpose are excluded to the extent permitted by law, and any and all implied warranties are excluded. This is the exclusive remedy and liability for consequential damages under any and all warranties are excluded to the extent exclusion is permitted by law.