

DAKE VERTICAL BANDSAW

Model V-26

INSTRUCTION MANUAL



Please record your saws information

 a Laguna Tools Company		VERTICAL BANDSAW	
MODEL	V-26	MOTOR	1.5 KW
WELDER	2.4 KVA	CONTROL VOLT	110 V
VOLTAGE	220 V	FREQUENCY	60 Hz
SER. NO	<input type="text"/>	DATE	<input type="text"/>
www.dakecorp.com			

DAKE CORPORATION
1809 Industrial Park Dr.
Grand Haven, Michigan 49417
Phone 800-937-3253
Web: www.dakecorp.com
E-mail : customerservice@dakecorp.com

DAKE V-26 TABLE OF CONTENTS

Forward	2-3
Installation and set up.....	3-4
Specifications	4-5
Operational Controls	6-7
Operation: Blade installation	7
Blade Tracking.....	8
Guide Post Adjustment.....	8
Guide Adjustment / Holder and Guide.....	9-10
Blade Selection / Type of Blades	10-11
Tooth Shapes	11
Set Types	11
Blade Selection Chart	12
Saw Speed & Pitch Selector	13
Welder Operation	14
Blade Cutting / Tooth Spacing.....	14
Welding of the Blade	15
Annealing (Carbon).....	15
Annealing (Bi-Metal)	16
Blade Dressing (Grinding)	16
Weld Inspection	17
Blade Weld Trouble Shooting	17-18
Trouble Shooting Chart / Saw /Blade / Cutting	18-20
Maintenance.....	20
Exploded Diagrams and Parts Lists	21-26
Electrical Drawing	27
Warning / Safety Labels	28
Circle Cutting Attachment Installation and setup	29-30

FOREWARD

First of all, we would like to take this opportunity to thank you for selecting our Dake V-26 model vertical Bandsaw.

As you know, the vertical bandsaw is a universal saw for contour cutting. Blade selection is important and by choosing the right blade, you can make most any pattern cutting on most any material with this machine. However, the most important thing is to realize how to operate it in a safe and correct way and how to maintain it.

We have tried to supply you all the information about these. Please be sure to look through all the contents in this manual so that you may obtain the maximum efficiency and the longest machine life with minimum expense.

The specifications and information in this manual were current at the time this manual was approved for printing. Dake, whose policy is one of continuous improvement, reserves the right, however, to change specifications or design at any time without incurring obligations.

Always include the part number, model number, and parts description, for parts orders or correspondence concerning your bandsaw, so we can supply you a rapidly after-sales service.

▲WARNING

1. Read the operator's manual carefully. Learn the tools applications and limitations, as well as the specific potential hazards peculiar to it.
2. Always wear approved safety glasses/face shields while using this machine.
3. Make certain the machine is properly grounded.
4. Before operating the machine, remove tie, rings, watches, other jewelry, and roll up sleeves above the elbows. Remove all loose clothing and confine long hair. DO NOT wear gloves when operating.
5. Keep the floor around the machine clean and free of scrap material, oil and grease.
6. Keep machine guards in place at all times when the machine is in use. If removed for maintenance purposes, use extreme caution and replace the guards immediately.
7. DO NOT over reach. Maintain a balanced stance at all times so that you do not fall or lean against blades or other moving parts.
8. Use only sharp blades. Dull blades are dangerous.
9. Make all machine adjustments or maintenance with the machine unplugged from the power source.
10. Use the right tool. Don't force a tool or attachment to do a job which it was not designed for.

11. DO NOT make cuts requiring more power than is available on the machine.
12. Replace warning labels if they become obscured or removed.
13. Make certain the motor switch is in the OFF position before connecting the machine to power.
14. Give your work undivided attention. Looking around, carrying on a conversation. And “horse-play” is careless acts that can result in serious injury.
15. Make a habit of checking to see that keys and adjusting wrenches are removed before turning on the machine.
16. Keep visitors a safe distance from the work area.
17. Use recommended accessories; improper accessories may be hazardous.
18. Never place hands directly in line with the saw blade.
19. Always use push sticks when cutting small material.
20. Raise or lower the blade guide only when the machine has been turned off and the blade has stopped moving.
21. Read and understand warnings posted on the machine.
22. DO NOT use attachments for any other purpose than for what they were designed for.
23. Failure to comply with all of these warnings could lead to serious injury.

INSTALLATION

WARNING!!!

The machine table must NOT be used as a lifting point. Damage to the saw could occur.

UNLOADING: Remove the shrink-wrap covering the machine, careful not to damage painted surfaces. **Carefully inspect the machine for physical damage. If damage is noted, notify the truck line at once. They may require inspection, and that a claim be filed.** Check that all standard accessories are with the machine. Some accessories may be boxed or placed behind the rear access door. The band saw is provided with a lifting eye that is screwed into the top of the machine. This lifting eye may be located in the rear compartment.

Particular care should be taken in selecting areas of the machine for handling, as electrical components and adjustment knobs can be marked up or damaged. Remove the mounting bolts holding the machine to the skid, using the lifting eye, remove the machine from the skid and set in designated area.

CLEANING

1. Remove anti-rust oil.
2. Remove the coating with a clean brush applied with appropriate solvent.
3. When the coating has been softened, remove it with clean rag.

POWER SUPPLY

1. Shut off the main power switch before connecting cable.
2. Check motor voltage against supply voltage.
3. Make sure the power supply is connected to comply with the local safety regulations.
4. Your saw may be pre-wired with a power cable attached. This cable can be hard wired or the preferred method of installing a properly rated quick disconnect.
5. The leads connect to L1, L2, and L3 and ground. The bandsaw must be grounded.
6. Check that the blade is running in the correct clockwise direction. If the blade runs backwards, disconnect the power. Then reverse any two of the three L1, L2, and L3 leads. Do not reverse the ground.

▲ WARNING

All electrical connections must be done by a qualified electrician. Failure to comply may cause serious injury!

All adjustment or repairs must be done with the machine disconnected from the power source. Failure to comply may result in serious injury!

SPECIFICATIONS

Capacity	26" X 13"
Blade Width Cap.	1/8" ~ 1"
Blade Speed	50 - 5,000 fpm
Table Size	23.5" x 27.5"
Table Tilt	R-45 ° , L-10 °
Main Drive Motor	230 volt 3 Phase, 3 HP
Grinder Motor	110V, 1 Phase, 0.04 KW
Blade Length	184"
Blade Welder Cap	4.2 KVA, 1/8" ~ 3/4"
Band Wheel Diameter	26"
Table Height	39"
Dimension	52 3/4" (Length) 31" (Width) 86" (Height)
Mach. Weight	1,466 lbs.

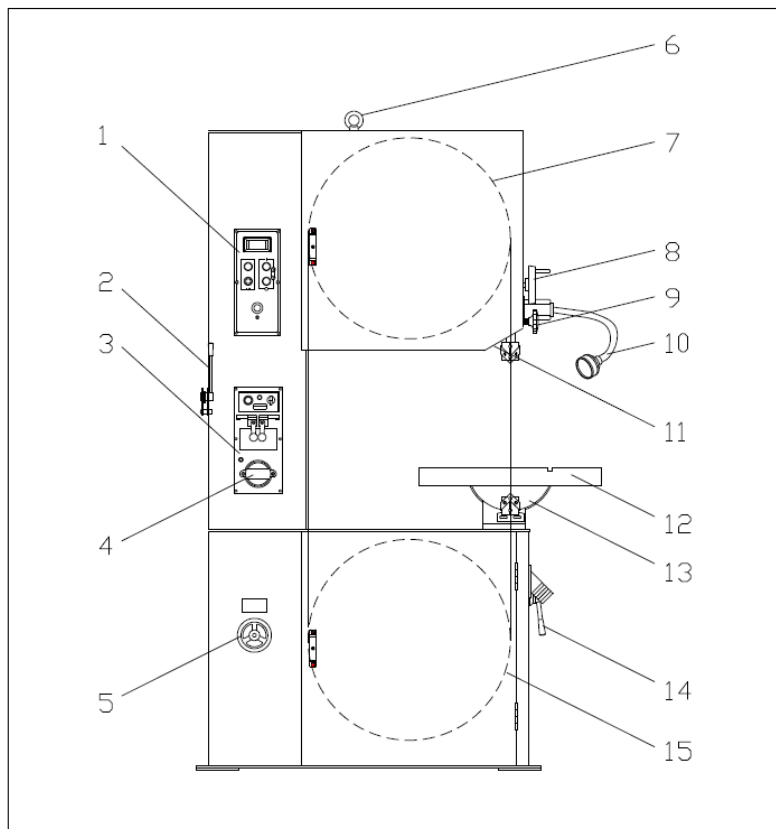
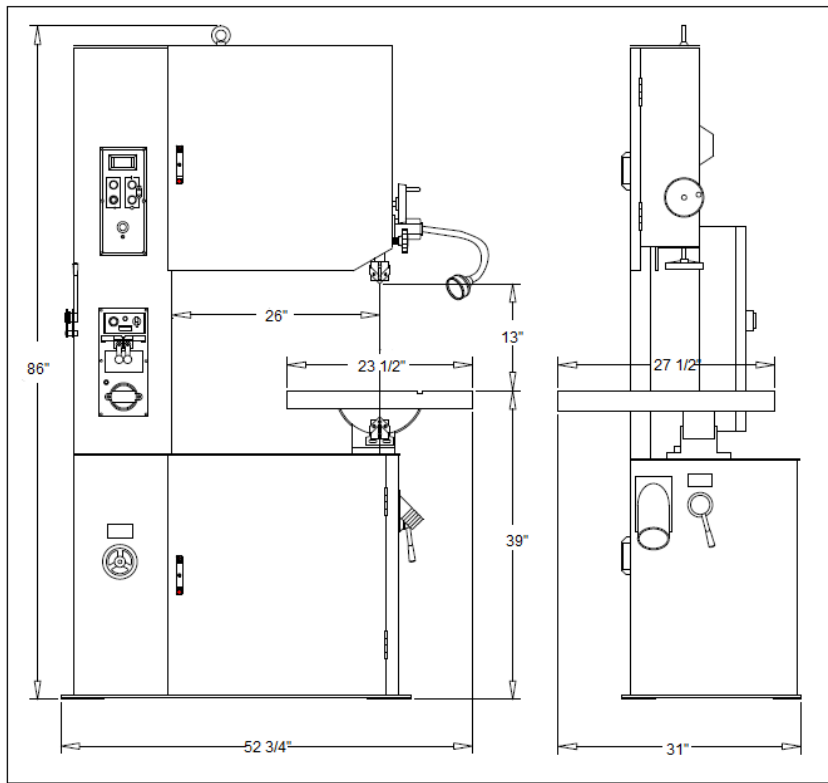

1	Control Panel	8	Guide Post Lifting Wheel
2	Blade Shear	9	Guide Post Locking Knob
3	Welder Panel	10	Work Lamp
4	Grinding Wheel Motor	11	Blade Guide Holder
5	Variable Speed Handwheel	12	Work Table
6	Lifting Eye	13	Table Support Housing
7	Upper Wheel	14/15	Low / High Range Lever, Lower Wheel

▲CONTROLS

Low/High Range Shift Lever –

Located on right side of machine base. Pull toward the front of the machine to shift into the low speed range. Push toward the rear of the machine to shift into the high-speed range. Caution: Do not change the speed range while the machine is running. Adjust only when the machine is stopped NOTE: If the lever will not mesh the speed range, slightly rotate the band wheel and the lever will go into gear.

Variable Speed Hand Wheel –

Located below the worktable on right side of machine base. Turn clockwise to increase speed and counter-clockwise to decrease speed.

Caution: Do not turn handle while machine is stopped. Adjust speed only when machine is running. RPMs will be displayed on the control panels digital readout.

Upper Guide Post Lock Knob –

Located on right side of upper frame. Turn counter-clockwise to loosen and clockwise to tighten. Always support the guide post when adjusting this knob to prevent unexpected dropping of the guide post.

Work Lamp Switch – Turn lamp on and off. Caution must be used as light will be hot.

Blade Shear Lever –

Located on upper left hand side of the column. Lever up position allows insertion of the blade into the shear. Pull lever downward to cut the blade. (This shear unit must be mounted during set up)

Grinder Toggle Switch –

Located on the blade welder panel found on columns front. Flip switch up to start grinder; flip down to stop grinder. This motor has temperature protection which will turn off the power automatically when the motor is over-heating. Motor will reset once it cools down.

Weld Button –

Located on the blade welders panel found on the front of the column. Depress and hold to start welding. Shuts off automatically when weld is done. Release when weld is completed

Anneal Button –

Located on the blade welders panel found on the front of the column. Depress and hold to anneal blade, release to stop.

Blade Clamp Pressure Knob –

Located on the blade welders panel found on front of the column. Sets pressure for different width blades.

Blade Clamps –

Located on the blade welder panel found on the front of the column. Down position allows insertion of the blade into the clamp. Up position locks blade

Blade Tension Hand Wheel –

Located on underside of the upper frame. Turn clockwise to tension the blade; counter-clockwise to release tension on the blade.

Blade Tracking Hand Wheel –

Located at the upper rear of the saw. Turn clockwise to track the blade toward front of the blade wheel Turn counter-clockwise to track blade toward rear of the blade wheel. (Do not let the blade ride up onto the wheel lip)

Table Tilt Mechanism –

Located under worktable. To tilt table left or right, loosen hex cap screws at the rear of the mechanism. Always tighten table bolts before operating the saw.

Power indicator Light –

Indicates that power to the control panel is on.

Key Lock Switch–

Turn the key to the 12 o'clock position and remove key to lock out power from the control panel.

System Fuse Holder –

Holds the fuse that renders the saw inoperable when blown.

Main Motor Start Switch –

Depress to start bandsaw.

Main Motor Stop Switch –

Depress to stop bandsaw.

Emergency Stop Switch –

Press to stop the machine. Turn knob 90° to reset.

Digital Readout- Located on control panel. Shows blade speed in feet per minute. Note: When starting up or changing speed, allow time for the readout to stabilize to the new setting.

OPERATIONS

BLADE INSTALLATION

1. Install the blade as illustrated through the guides and onto the upper and lower wheels. Replace any guarding that was removed after blade is installed.
2. Adjust blade tension per the tension scale by turning the blade tension adjustment hand wheel. The scale is visible from the rear side.
3. Jog the machine to see if the blade tracks properly, adjust blade tracking by turning the tracking adjuster when it is necessary. (See blade tracking section on next page for further details)

Proper tensioning

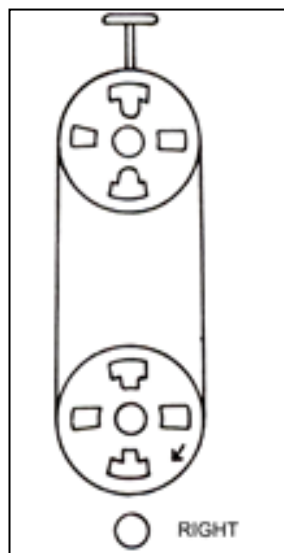

Improper tensioning

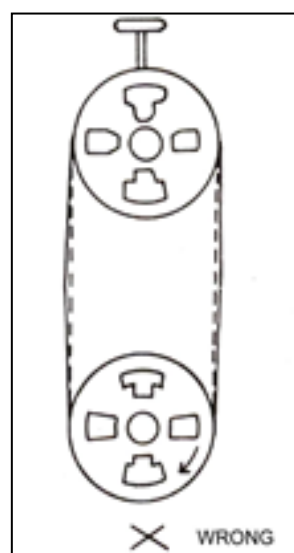

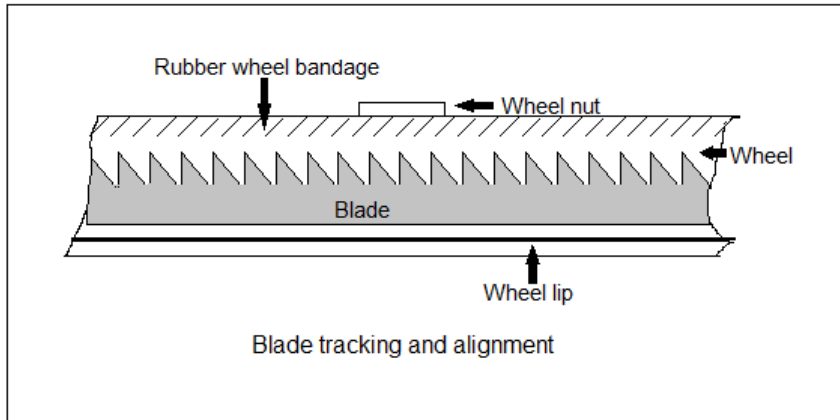

BLADE TRACKING

Blade tracking may be required from time to time depending on the blade size and tension. Disconnect the machine from the power source and open both blade wheel doors. Shift the high-low gearbox lever into the neutral position. Turn the upper blade wheel by hand while observing blade position on the upper blade wheel to determine if adjustment is necessary:

- Turn blade tracking knob clockwise to track blade toward front of blade wheel.
- Turn counter-clockwise to track blade toward rear of blade wheel. Blade should be tracked as close of the center of the top blade wheel as possible. Do not allow blade to run on the wheel lip.

▲Note: Upper and lower blade guides should be moved away and left loose from the blade while tracking adjustments are being made.

GUIDE POST ADJUSTING

- Loosen the guide post locking knob. Always support the guide post when loosening the guide post to prevent it from unexpectedly falling. (Figure A next page)
- The height of the upper guide post setting is in relationship to the height of the material. The height between the material and the blade guide end is suggested to be about 1/4". (See figure B illustration on next page)
- Lock the guide post tightly.

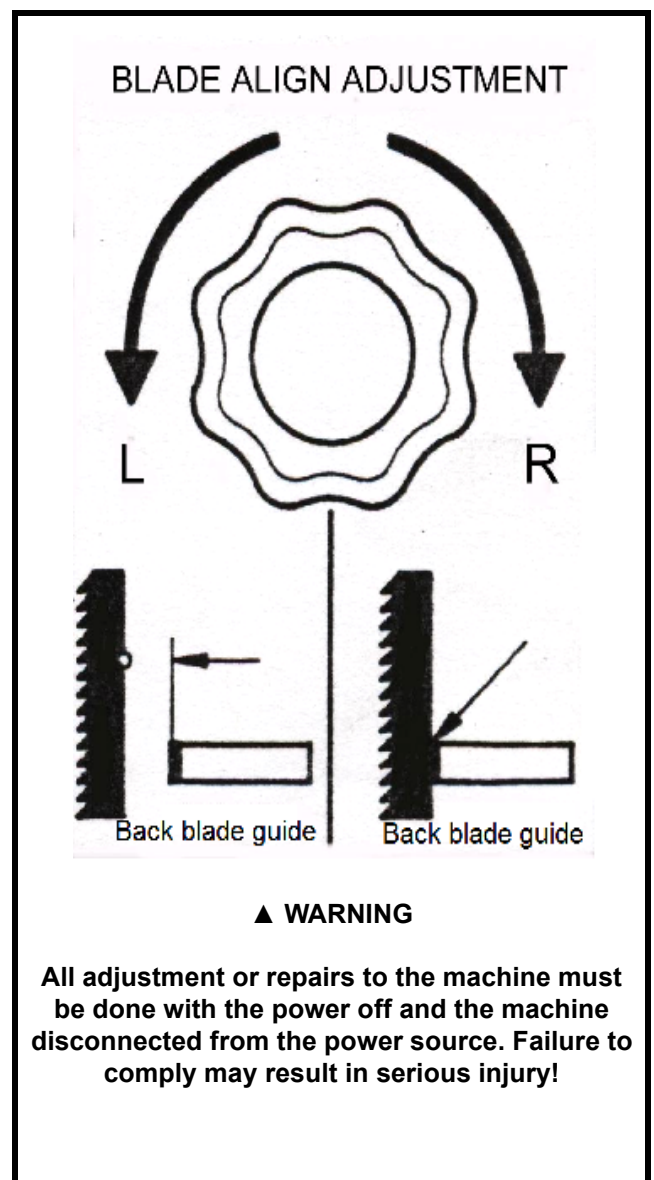

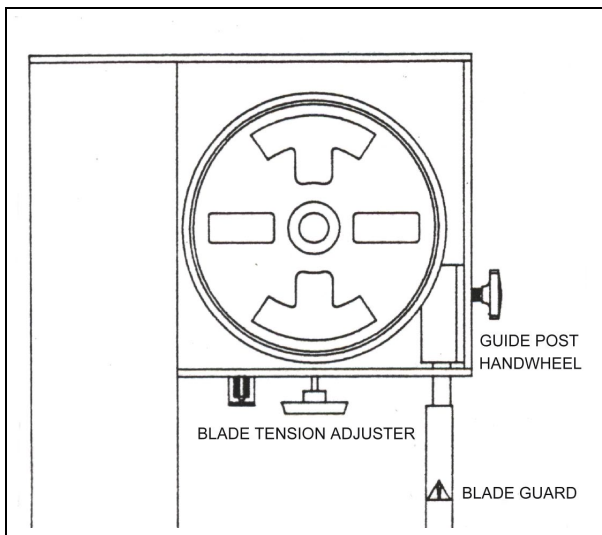

Figure A

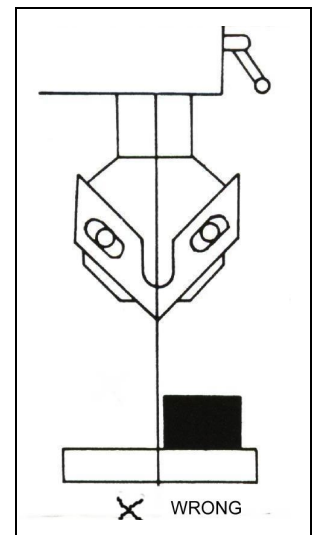
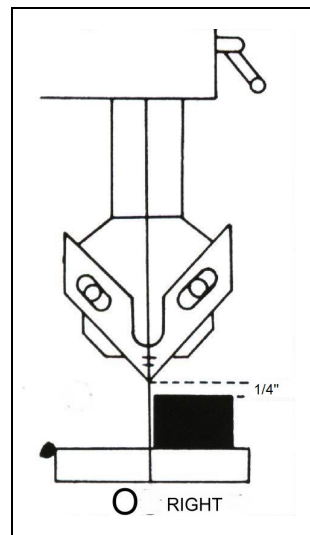
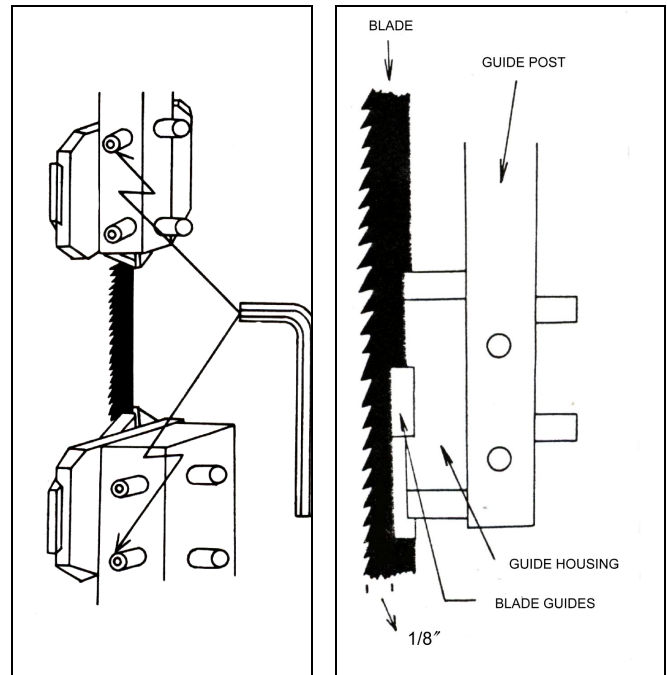

Figure B

▲ It may be necessary to open the blade guides, before you adjust the guide post to allow free movement of the guide post.

GUIDE HOLDER ADJUSTMENT

1. Loosen the inner hex screws located at the right lower side of guide post with an "L" shaped allen wrench.
2. Adjust the guide holder forward or backward according to the blade width. The front edge of the blade guides must be adjusted about 1/8" behind the blade teeth. (see figure B next page)
3. Tighten the screws securely.



BLADE GUIDE ADJUSTING

1. Loosen the inner hex screws of the blade guide with an "L" shaped allen wrench.
2. Adjust the blade guides very close to the blade but not touching the guide faces. (approx. thickness of a business card)
3. With blade tight allow guides to ride up to the blade not forcing them off center. Tighten the blade guides securely. (See figure A next page)

NOTE: There are a total of four blade guides and two guide holders located above the table and under the table, all to be adjusted to the same position.

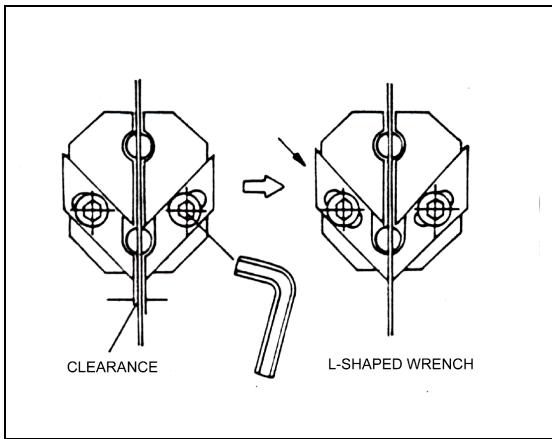

Figure A

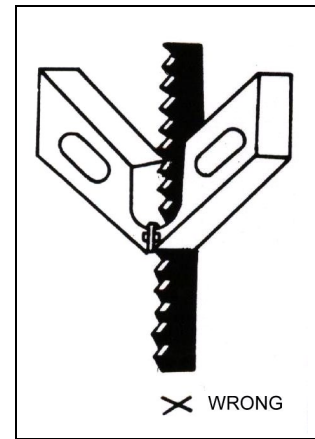
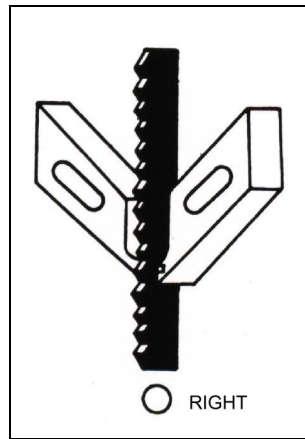
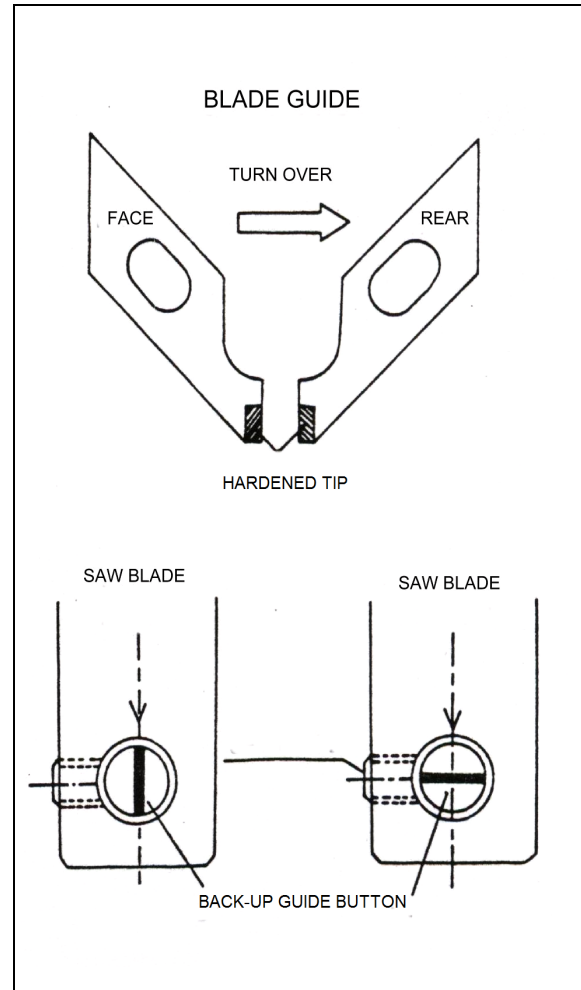

Figure B

The blade guides will wear after time at the front faces. If the blade guides become hard to be properly adjusted, turn the left blade guide over to the right side, as illustrated in the right illustration, and turn the right-side blade guide over to the left side as well. The blade guides can then be used on both sides getting more mileage out of the guides.

The backup blade guide button will wear over time as friction from the saw blade may cause a worn line on its surface. If this is found to happen, loosen the lower guide holder bolt and turn it to rotate the button shaft to change the buttons position on the saw blade.



▲ CAUTION

Blade guide must be properly adjusted or damage may occur to the blade and/or the guides.

BLADE SELECTION

To get the most satisfactory work from your saw, it is important to choose a blade that is correct for the work. Blade life, cut straightness, finishing quality and sawing efficiency is all related to the choice of blade. Blade breakage, teeth stripping, crooked cuts, and other common complaints are, in most instances, caused by using the wrong blades. Blades are classified by materials, tooth shapes, and types of set.

TYPES OF BLADES

Bandsaw blades are available in specific sizes, or in 100 feet coils. They are made from several different metals:

1. Carbon Steel Blade: which are widely used because of their general adaptability for all types of work and the low cost. They are excellent for cutting nonferrous metals and plastics.
2. High-Speed Steel Blade: which resist heat generated in cutting to far greater extent than carbon steel blades. They are best suited for cutting ferrous metals.
3. Alloy Steel Blade: which are tougher and more wear resistant than either of the above. They will cut faster and longer than blades of carbon or high-speed steel.
4. Carbide-Tipped Blade: which are best used for cutting unusual materials such as uranium, titanium, and beryllium. These metals are difficult to cut with other types of blades.

TOOTH SHAPES

The regular or standard tooth is preferred for all ferrous metals and general-purpose cutting. The skip-tooth blade has widely spaced teeth to provide the added chip clearance needed for cutting softer nonferrous materials. The hook, or saber tooth blades has a 10° undercut which permits better feed and chip removal, it is best for the harder nonferrous alloys.

SET TYPES

Regular or rake set is generally furnished on saws that have 2 to 24 teeth per inch. These blades have one tooth set to left, one to right, and one unset tooth called a rake. This set is used when material is to be contour cut. Wavy set is furnished on saws that have 8 to 32 teeth per inch. This set has groups of teeth bent alternately to left and right, which greatly reduce the strain on individual teeth. Saws with wavy set are used where tooth breakage is a problem, such as in cutting thin stock or where a variety of work is cut without changing blades.

Of the three common set patterns, only raker and wave are now used in metalworking.

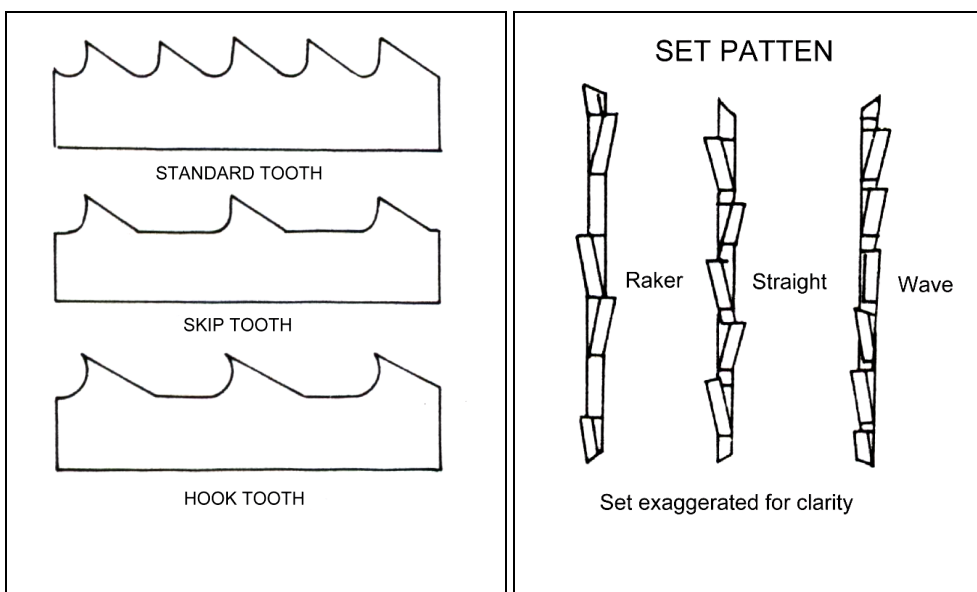

Always use rake set except:

For work of varying cross section use wave set.

When one blade must be used for a range of material sizes use wave set

▲ PLEASE NOTE THAT CORRECT BLADE SELECTION IS VERY IMPORTANT TO BANDSAW OPERATING AT FULL POTENTIAL. ALWAYS SELECT A BLADE ACCORDING TO THE MATERIAL SHAPE AND THICKNESS OF THE WORK

Always break in the blade per blade manufactures recommendations.

SAW BLADE SELECTION

	MATERIAL SHAPE	MATERIAL SHAPE	MATERIAL SHAPE
MATERIAL IN	■	●	○ H ^
INCHES	TOOTH SELECTION	TOOTH SELECTION	TOOTH SELECTION
0	14 / 18	14 / 18	14 / 18
.1	14 / 18	14 / 18	14 / 18
.2	14 / 18	14 / 18	14 / 18
.3	10 / 14	14 / 18	10 / 14
.4	8 / 12	10 / 14	8 / 12
.5	8 / 12	8 / 12	6 / 10
.6	6 / 10	8 / 12	5 / 8
.7	6 / 10	6 / 10	5 / 8
.8	5 / 8	6 / 10	5 / 8
.9	5 / 8	5 / 8	5 / 8
1	5 / 8	5 / 8	4 / 6
1 1/4	4 / 6	5 / 8	4 / 6
1 1/2	4 / 6	4 / 6	4 / 6
1 3/4	4 / 6	4 / 6	4 / 6
2	4 / 6	4 / 6	3 / 4
2 1/4	4 / 6	4 / 6	3 / 4
2 1/2	3 / 4	4 / 6	3 / 4
2 3/4	3 / 4	4 / 6	3 / 4
3	3 / 4	3 / 4	3 / 4
3 1/4	3 / 4	3 / 4	3 / 4
3 1/2	3 / 4	3 / 4	3 / 4
3 3/4	3 / 4	3 / 4	2 / 3
4	3 / 4	3 / 4	2 / 3
5	2 / 3	3 / 4	2 / 3
6	2 / 3	3 / 4	2 / 3
7	2 / 3	2 / 3	1.4 / 2.5
8	1.4 / 2.5	2 / 3	1.4 / 2.5
9	1.4 / 2.5	2 / 3	1.4 / 2.5
10	1.4 / 2.5	1.4 / 2.5	1.4 / 2.5
11	1.4 / 2.5	1.4 / 2.5	1.4 / 2.5
12	1.4 / 2.5	1.4 / 2.5	1.4 / 2.5

Please refer to the “Speed & Pitch Selector wheel that is supplied on your saw for speeds and feeds, radius cutting and blade pitch selection.

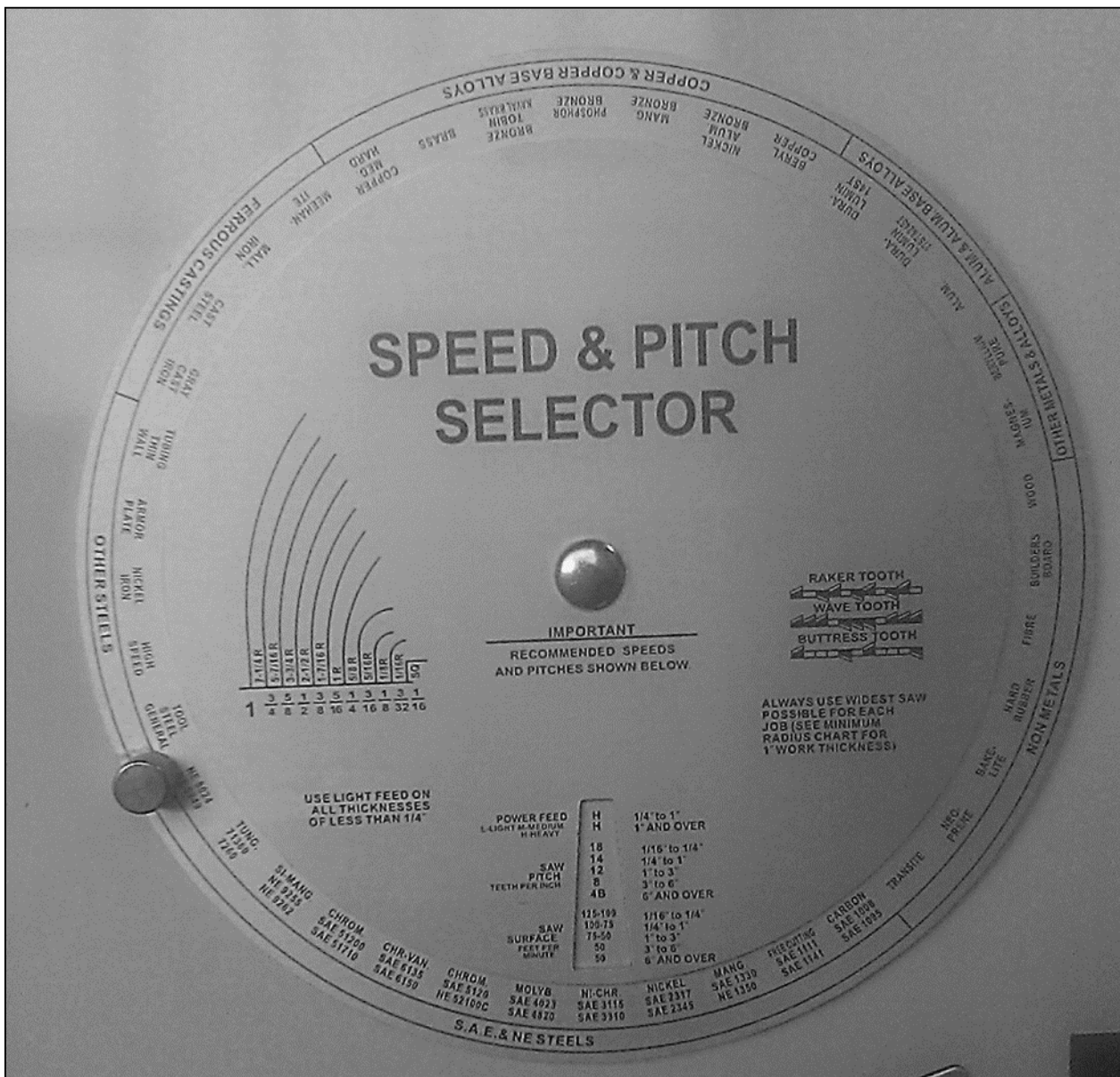

Select saw blades in relationship to the thickness of materials. The following suggestions are a rule of thumb to consider when selecting a blade.

- A. Select a larger pitch blade for a thicker material.
- B. Select a smaller pitch blade for a thinner material.
- C. Use a smaller pitch blade to obtain a smooth cutting surface.
- D. Use a larger pitch blade to obtain a faster cutting speed.
- E. It is important to have different blades for different applications

WELDER OPERATION

This welder is for occasional use for blade repair and is not intended for welding blades on a regular basis from bulk stock. This welder is best suited for carbon bands but with practice both carbon and bi-metal can also be welded.

BLADE CUTTING

1. Cut the blade to the length of the machine. Using the blade shear will insure that the blade ends are cut flat, square and smooth.
2. Place the back edge of blade against the square cutting guide of the shear and firmly pull the cutting lever down to shear the blade. Both ends of the blade must be sheared to allow for a good butt weld.
3. Keep the shear blade clean and free from blade end pieces that can get trapped in the shear.

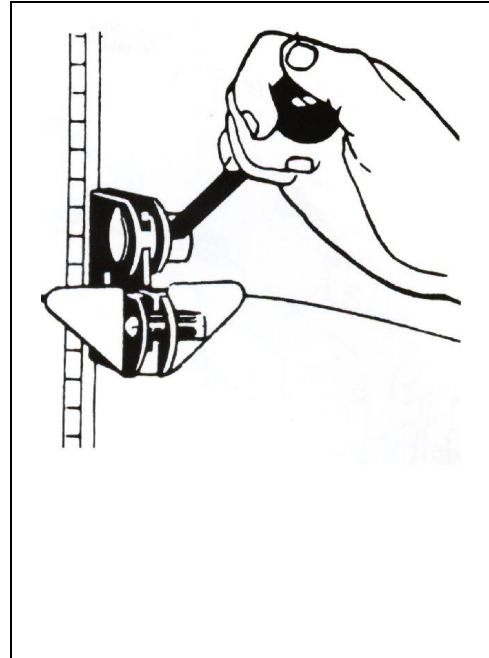

Using the Blade Shear.

TOOTH SPACING

1. On fine-pitched blades, one or more teeth on each side of the cut must be removed by grinding so that the cross section of the weld area of the blade is uniform. Following these guidelines will help make the teeth uniformly spaced after the weld.

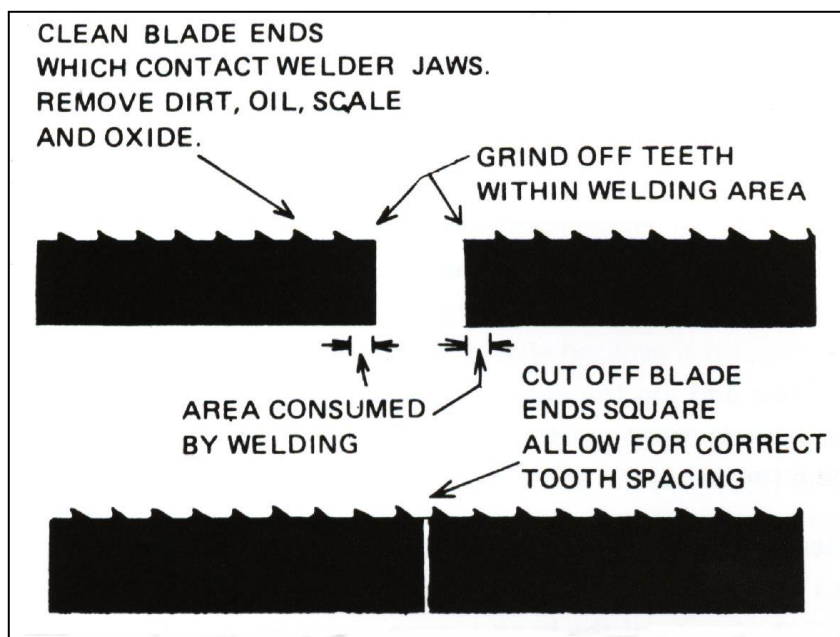

▲ **CAUTION:** If the saw blade is rusty, the rust must be ground off before the blade is welded.

WELDING

1. Turn pressure knob to "0" position.
2. Butt blade ends together and locate joint in the center between the two electrodes.
3. Set pressure knob to blade width. (Due to the different materials and thickness of blade, please pay especial attention to the pressure adjustment. Thicker the blade higher the pressure setting.)
4. Press and hold welder button. Do not release until the blade joint is "red" hot. The switch is automatic and will shut welder off after a preset time of 3 or 4 seconds and the blade returns to original color. **Note: The weld joint may throw sparks during welding so wear safety glasses and proper apparel.**

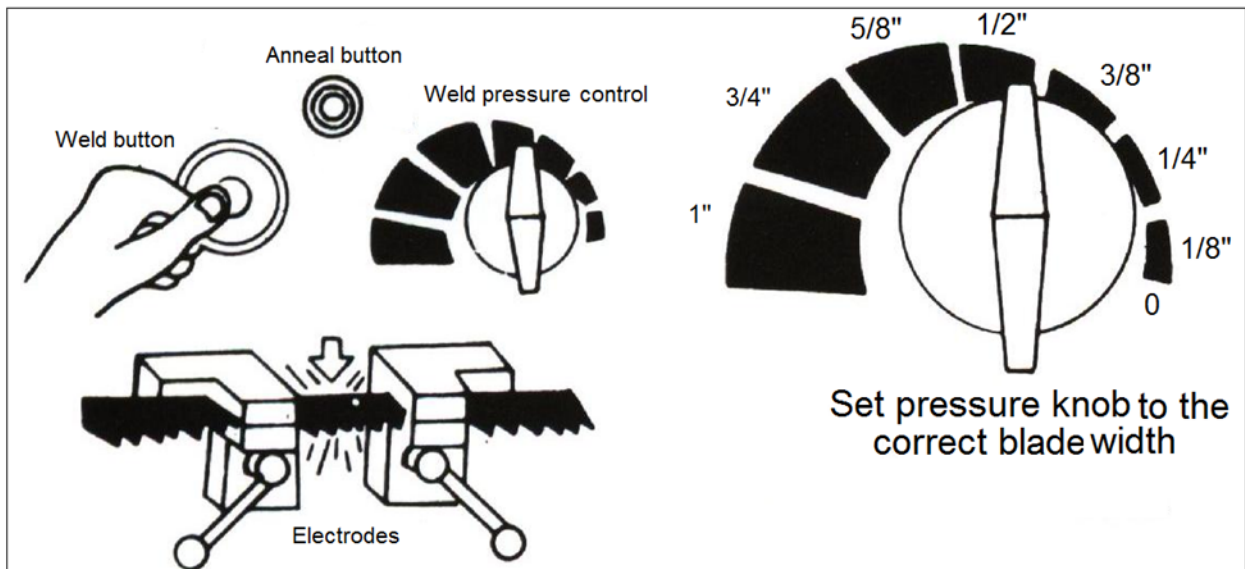

ANNEALING (Carbon Blades)

1. Turn pressure knob to "0" position.
2. Release blade and center the weld joint at the front of the electrodes. (At the wider part)
3. Press and jog the annealing switch button until the weld is a "dull cherry" to "cherry red" color. Allow the blades to cool slowly by decreasing the jogging frequency.
4. Perform the annealing operations 4 or 5 times, gradually reducing the heat each time.
5. Remove any welding dust or scale from the joint and anneal 2 or 3 more times, successively at lower temperatures. (quicker series of press and release of annealing button)

ANNEALING (Bi-Metal)

Set up blade for annealing as mentioned above for carbon blades steps 1 & 2.

Heat the band slowly by jogging the annealing switch button until the weld just begins to emit light (this would be the dull red color) or minute puff of smoke. The desired color may not be visible in normal room light. Always shade the weld area with your hand. Cool the weld quickly by releasing the annealing button. Repeat this operation 4 or 5 times.

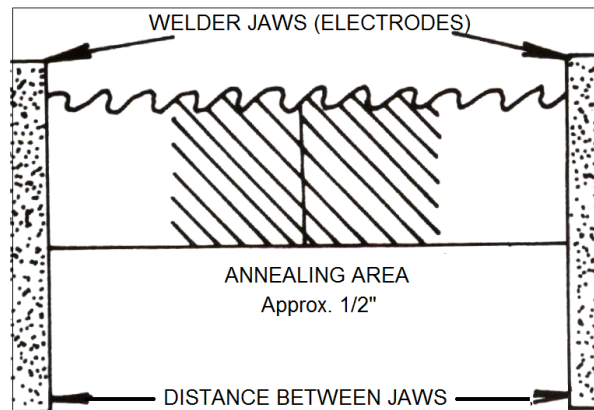

▲ NOTE: This procedure should be followed both before and after grinding BI-METAL Blades.

GRINDING THE WELDED BLADE

▲ WARNING

Keep hands away from rotating grinding wheel. When not in use make, sure wheel is covered with built in cover

After welding, the blade must be dressed to remove excess metal or flash from the weld. Grind the welded area down to the same thickness as the rest of the band. Handle the blade carefully.

Grind Carefully: do not hit the teeth; or grind deeper than the thickness of the blade; or overheat the weld area. Be sure to remove flash from the back edge of the blade. Any flash or “stub” teeth that project beyond the normal set or height of the other teeth must be ground off.

Anneal the welded area that was ground again. Anneal 2 or 3 times using a lower temperature. (Just as area starts to emit light)

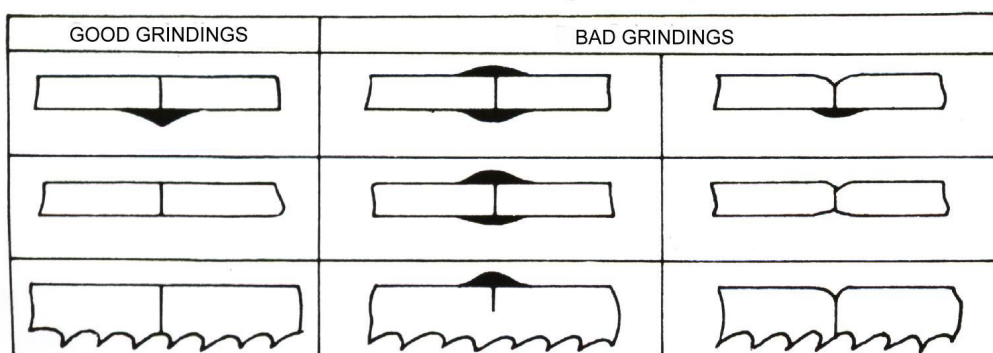

INSPECION OF THE WELD

When the blade is removed from the welder it should be inspected carefully.

The spacing of the teeth should be uniform and the weld should be located in the center of the gullet. Major jaw misalignment is easily noted at this time from the weld appearance. See the trouble shooting chapter if the weld is imperfect.

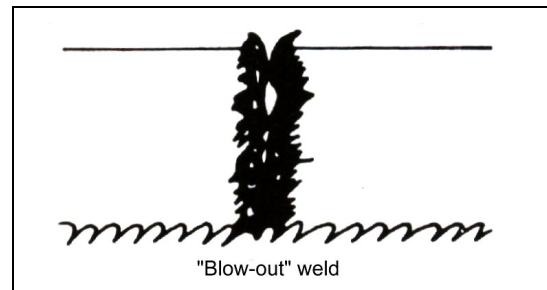
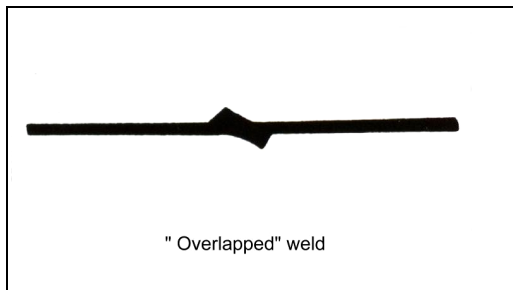
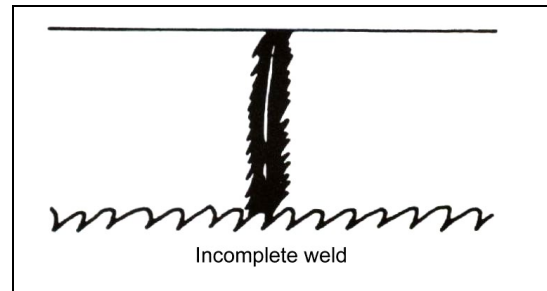
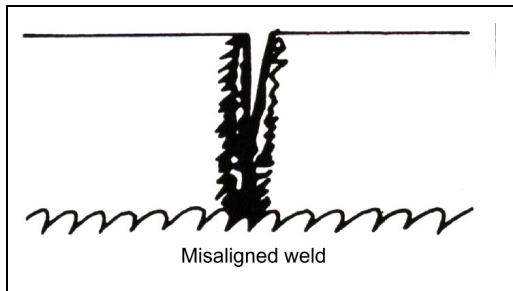
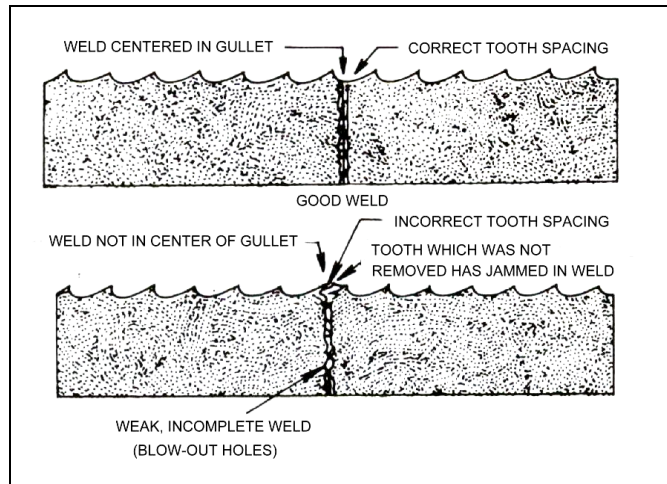

▲ CAUTION: This welder is designed for intermittent use. Repeated welding within a short period of time may cause the welder to overheat.

TROUBLE SHOOTING

MISALIGNED WELD

- (1) Dirt or scale on jaws or blade.
- (2) Blade ends not cut off square.
- (3) Blade ends not correctly aligned when clamped in jaws.
- (4) Worn jaws or inserts.
- (5) Jaws are not aligned correctly.

MISALIGNED WELD-BLADE ENDS ARE OVERLAPPED

- (1) Jaw Upset Force Control set for wider blade than used, re-adjust correctly.
- (2) Blade ends or jaws not aligned correctly.

WELD BREAKS WHEN USED

(Joint is not complete, “blow holes” in joint)

- (1) Weld not annealed correctly.
- (2) Weld has been ground too thin.
- (3) Weak “Incomplete” weld.

INCOMPLETE WELD (Items 3 – 8 requires welder removal)

- (1) Incorrect Initial Set-Up:
 - (a) Initial jaw gap (weld lever position) not set correctly.
 - (b) Upset force control not set correctly.
- (2) Improper clamping procedures.
- (3) Defective cut-off switch may not break the circuit at end of welding operation.
- (4) Cut-off Switch not adjusted correctly.
- (5) Points of cut-off switch welded together.
- (6) Slide Rod sticking because of rust or dirt. Clean and oil the rod.
- (7) Slide Rod movement obstructed because the stop screw too tight on the Rod.
- (8) Jaw movement obstructed by kinked jaw cable or tangled wires. Bend cable and untangle wires.

BRITTLE WELDS

Weld has not been annealed correctly; see “Annealing” in operation chapter. Poor annealing can be caused by:

1. Incorrect annealing heat. Bring weld up to correct color as described under “Annealing” in welder operations chapter.
2. Scale or oil on weld can cause poor annealing.

TROUBLE SHOOTING

PROBLEM	CAUSE	SOLUTIONS
The Weld could not be made, the Jaws do not move	A. The wire connection is poor, the connecting point of welding switch is bad B. The transformer is burnt out C. Some oil is on the blade D. Some rust is on the blade ends E. The adjustment of the welding pressure is incorrect	A. Change the welding switch. B. Change the transformer. C. Remove the oil D. Grind off the rust E. Loosen the adjusting screw that is in center of it
The weld area melts the blade not welds it when welding switch is pushed	A. The welding switch cut off too late B. The Welding Pressure is too weak C. The jaw movement is too slow	A. Screw the welding switch Connecting Nut tight B. Turn the welding pressure adjuster clockwise C. Put some oil on the rear side of the welding lever jaws

The annealing job cannot be made when pushing the anneal button	A. The connection of annealing switch is loose or broken B. The fuse is blown C. The connection of the electrodes to blade is poor	A. Change an anneal switch B. Change a fuse C. Clean electrode surfaces
The grinder is not running when the grinder switch on	A. The grinder motor is defective B. The grinder switch is defective	A. Replace the grinder B. Replace the switch
The blade can not be tightly clamped with the jaw clamps	A. The jaw clamps are burnt or defective B. The lower jaw inserts defective C. The Jaws are burnt or eroded	A. Change clampers B. Change lower jaw Inserts C. Change jaws
The annealing button will not release to neutral position	Some dust or debris around the anneal button restricting movement	Release the anneal button by gently pulling it to the neutral position Clean out any dust or debris
Blade tooth broken	A. Incorrect pitch for the application B. Brittle blade improper annealing C. Inferior blade	A. Select a right pitch blade B. Re-weld and anneal C. Decrease feeding rate D. Change to high quality blade
Blade damaged	A. Brittle blade improper annealing B. Blade tension out of adjustment C. Too Fast feeding D. Blade teeth hitting guides. E. Cannot cut radius without blade twisting.	A. Decrease the annealing temperature B. Adjust blade tension C. Decrease feed rate D. Adjust a proper gap between the blade and the guide insert E. Change to a narrower blade

PROBLEM	CAUSE	SOLUTIONS
Saw blade is twisted	A. Improper weld B. Blade installed in improper way C. Blade tension too loose D. The blade is being over fed	A. Re-weld the blade again B. Set the guide inserts closer C. Increase blade tension D. Decrease the feeding rate when starting the cut E. Use a proper width blade for radius cutting
The sawing direction deviates	A. The blade tooth is not on even or worn unevenly. B. The blade tension is too loose C. The guide post was set too high	A. Make sure a good blade is used without damaged teeth B. Increase blade tension C. Set the guide post to be within a 1/4" of the work D. Decrease feeding rate
Saw blade walks off	A. Blade tension is too loose B. Blade is not tracked properly	A. Increase blade tension B. Adjust the wheel alignment

The blade dulling prematurely	A. The blade speed is too fast B. The selection of blade is improper C. Feeding rate too fast	A. Slow down the blade speed B. Use a proper blade for the application C. Decrease feeding rate
The blade is not cutting straight vertically	A. The blade dull B. The guide post is not properly fixed C. The blade tension is too loose D. The blade is not exactly 90° to the table	A. Change to a new blade B. Fix the guide post properly ¼" above material C. Increase blade tension D. Adjust it to be 90°
Excessive noise when machine is running	A. The variable speed pulley is damaged C. The saw is not sitting flat on the floor	A. Change a new pulley B. Reposition the machine on a flat even hard floor

MAINTENANCE

PART OR PLACE TO BE OILDED OR GREASED	TYPE OF OIL OR GREASE	LUBRICATING PERIOD	REMARKS
Bearings	Gear oil	every 6 months	Gear Box:
Guide post sliding part	Grease	weekly	#1350 & #1360
Speed Change handle	Grease	every 6 months	#0600, #0740, #7120 & #7290
Gear and thread	Grease	every 3 months	#7080 & 7110
Variable pulley	Grease	N/A	#9995: V-16 only
Table slide shaft	Machine oil	daily	#1250: E-type only
Upper wheel slide block	Machine oil	monthly	#3100 & #3110
Blade Tension Screw	Grease	monthly	#3110 & #3120
Welder Jaw			(clean up daily)
Rubber Tire			(clean up daily)
Work Table Assembly			(clean up daily)

GEAR BOX COMPONENT	
0500V26	1 * GEAR BOX
0510V26	1 * GEAR BOX COVER 303243
0520V26	1 * GEAR
0521V26	1 * GEAR
0530V26	1 * SCREW NUT
0531V26	1 * SCREW NUT
0540V26	1 * GEAR 303245
0550V26	1 * GEAR SHAFT
0560V26	1 * SHAFT COVER
0570V26	1 * GEAR 303244
0580V26	1 * MAIN SHAFT
0591V26	1 * MAIN SHAFT COVER
0600V26	1 * SPEED CHANGING SHAFT
0610V26	1 * SPEED CHANGING ARM
0611V26	1 * SHAFT STOPPER
0612V26	1 * SPRING
0620V26	1 * SLIDE BLOCK
0630V26	1 * CLUTCH
0631V26	2 * BRASS BRACKET
0632V26	1 * BRASS BRACKET
G6008V	1 * BALL BEARING
G6206V	1 * BALL BEARING
G6303V	1 * BALL BEARING
G6304V	1 * BALL BEARING
L4030V	1 * OIL SEAL
L5230V	1 * OIL SEAL
L5840V	1 * OIL SEAL
CP0500V	1 GEAR BOX COMPLETE 303242
0700V26	1 SPEED CHANGING LEVER
0740V26	1 SHAFT HOUSING
0790V26	1 SPEED LEVER RIGHT
7071V26	1 PULLEY 303228
9220V26	1 LEVER KNOB
BA44V26	2 V-BELT, 7071+7300 (60HZ)
BA45V26	2 V-BELT, 7071+7300 (50HZ)

GUIDE POST COMPONENT	
1311V26	1 GUIDE SUPPORT, UPPER
1312V26	1 GUIDE SUPPORT, LOWER
1320V26	4 BLADE GUIDE 303233
1331V26	1 BLADE STOPPER, LONG 303251
1332V26	1 BLADE STOPPER, SHORT 303263
1333V26	1 ECCENTRIC SHAFT
1350V26	1 BLADE GUIDE POST
1351V26	1 GEAR BAR
1360V26	1 GUIDE POST HOUSING
1370V26	1 BLADE GUARD, LEFT
1380V26	1 BLADE GUARD, RIGHT
1400V26	2 SPRING
1410V26	1 SPRING HOUSING
1440V26	1 POST HOUSING SPRING
1450V26	1 POST ELEVATING GEAR
1650V26	1 CIRCLE CUTTING ATTACHMENT
9015V26	1 GUIDE POST LOCK
9033V26	1 POST ELEVATE HANDWHEEL
9230V26	1 HANDLE KNOB
G6201V26	1 BALL BEARING

MAIN DRIVE

2000V26	1 MAIN DRIVE MOTOR 303255
2011V26	1 MOTOR PULLEY
2020V26	4 MOTOR ROTARY SEAT
BA43V26	2 V-BELT, 2011+7070
BA60V26	1 V-BELT, 2011+4450

WHEEL COMPONENT

3010V26	1 * LOWER WHEEL
3020V26	1 * RUBBER TIRE 303261

WORK TABLE COMPONENT

1010V26 1 WORK TABLE
 1020V26 1 TABLE SUPPORT FRAME
 1080V26 2 BLADE GUARD

CP3010V26 1 LOWER WHEEL COMPLETE
 3030V26 1 TAPER SLEEVE
 3040V26 1 WHEEL LOCKING NUT
 3020V26 1 * RUBBER TIRE
 3050V26 1 * UPPER WHEEL

WORK TABLE CONTINUED

1090V26 1 TABLE SUPPORT HOUSING
 1100V26 1 GUIDE SUPPORT HOUSING
 1120V26 1 RIGHT-HANDED SCREW
 1140V26 1 LEFT-HANDED SCREW
 1150V26 1 SLIDER
 1160V26 1 TABLE TILT ADJUST SCREW
 1500V26 1 MITER GAUGE **304068**
 1550V26 1 RIP FENCE + LOCK **303256**
 1800V26 1 FEED SCREW

G6305V26 2 * BALL BEARING
CP3050V26 1 UPPER WHEEL COMPLETE
 3060V26 1 UPPER WHEEL LOCK

WHEEL COMPONENT CONT.

1140V26 1 LEFT-HANDED SCREW
 1150V26 1 SLIDER
 1160V26 1 TABLE TILT ADJUST SCREW
 1500V26 1 MITER GAUGE **304068**
 1550V26 1 RIP FENCE + LOCK **303256**
 1800V26 1 FEED SCREW

3080V26 1 * SLIDE BLOCK HOUSING
 3090V26 1 * SLIDE BLOCK SEAT
 3100V26 2 * SLIDE BLOCK GUIDE
 3110AV26 1 * UPPER WHEEL SLIDER
 3116V26 1 * SLIDER SCREW SHAFT
 3120V26 1 * WHEEL ELEVATE SHAFT
 3121V26 1 * SPRING
 3150V26 1 * WASHER

AIR PUMP COMPONENT

4060V26 2 AIR PUMP SEAT
 4170V26 1 AIR NOZZLE
 4180V26 1 AIR NOZZLE CLIPPER
 4450V26 1 AIR COMPRESSOR **303229**

3180V26 3 * INDICATOR RING
CP3080V26 1 SLIDE HOUSING COMPLETE
 3190V26 1 TENSION INDICATOR
 3200V26 1 WHEEL TILT ADJUSTER
 3220V26 1 WHEEL TILT CONNECTER
 3240V26 1 CONNECTER WASHER
 3250V26 1 CONNECTER HOUSING
 9030V26 1 HANDWHEEL
 9060V26 1 TILT ADJUST HANDWHEEL

MAIN BODY & MISCELLANEOUS

5000V26 1 MAIN BODY
 5100V26 1 REAR DOOR, LARGER
 5101V26 1 REAR DOOR, SMALLER
 5120V26 1 LOWER DOOR
 5140V26 1 UPPER DOOR
 8111V26 1 CONTROL PLATE **303905**
 8372V26 1 VARIATOR INSTRUCTION
 8422V26 1 GEAR BOX INSTRUCTION
 8712V26 1 INDICATOR PLATE
 8743V26 1 TILT INSTRUCTION
 9300V26 2 UPPER DOOR HINGE
 9310V26 6 HINGE
 9500V26 4 SPRING PLATE
 9590V26 2 HANDLE ARM
 9600V26 1 CHIP STOPPER
 9700V26 1 INDICATE MIDDLE
 9780V26 1 BRUSHER BRACKET
 9790V26 1 CHIP BRUSHER **303237**
 9850V26 1 KEY FOR REAR DOOR
 9880V26 1 CHIP COLLECTOR

VARIATOR COMPONENT

7000V26 1 MOTOR SPRING HOUSING
 7010V26 1 * SPRING
 7020V26 1 * VAEIATOR DISK, UPPER
 7030V26 1 * VAEIATOR DISK, UPPER
 7040V26 1 * VARIATOR HOUSING TUBE
 7050V26 1 * VARIATOR SHAFT
 7060V26 1 * VARIATOR HOUSING
 1 * BALL BEARING
 G6007V26 2 * BALL BEARING
CP7060V26 1 VARIATOR HOUSING
 7070V26 1 PULLEY
 7080V26 1 WORM GEAR
 7090V26 1 WORM GEAR HOUSING
 7100V26 1 GEAR SHAFT

9900V26	1	MAGNIFYING GLASS	7110V26	1	WORM
			7120V26	1	WHIRLING ARM
			7200V26	1 *	SPRING HOUSING
			7210V26	1 *	SPRING
			7220V26	1 *	VARIATOR DISK, LOWER
			7230AV26	1 *	VARIATOR DISK, LOWER
			7260V26	1 *	SHAFT HOUSING
			G6007V26	1 *	BALL BEARING
			G6204V26	1 *	BALL BEARING
			CP7260V26	1	SHAFT HOUSING
			7290V26	1	SPEED CHANGE WHEEL SEAT
			7300V26	1	PULLEY
			7310V26		SPEED READOUT DETECTOR 303264
			7330V26		DIGITAL TACHOMETER 303238
			9030V26		HANDWHEEL
			BA44V26		V-BELT, 7071+7300 (60HZ)
			BA45V26		V-BELT, 7071+7300 (50HZ)
			BA43V26		V-BELT, 2011+7070
			BV875V26		V-BELT
CONTROL SWITCH COMPONENT					
6600V26	1	PUSH BUTTON, ON			
6602V26	1	PUSH BUTTON, OFF,			
6610V26	1	EMERGENCY SWITCH			
6620V26	2	DOOR LIMIT SWITCH 303239			
6650V26	1	KEY SWITCH			
6700V26	1	MAIN POWER SWITCH			
6713V26	2	MAGNETIC SWITCH 303254			
6723V26	1	OVERLOAD STARTER 303258			
6741V26	1	PILOT LAMP, GREEN			
6745V6	1	VOLTAGE REDUCER 303266			
6713V26	2	MAGNETIC SWITCH 303254			
6723V26	1	OVERLOAD STARTER 303258			
6741V26	1	PILOT LAMP, GREEN			
6745V6	1	VOLTAGE REDUCER 303266			
6752V26	1	FUSE SEAT			
6753V26	2	FUSE SEAT			
6754V26	1	FUSE SEAT			
6770V26	2	WIRE HOUSING			
6771V26	1	GROUND SEAT			
6798V26	1	ELECTRIC BOX			
6799V26	1	WIRING PLATE			

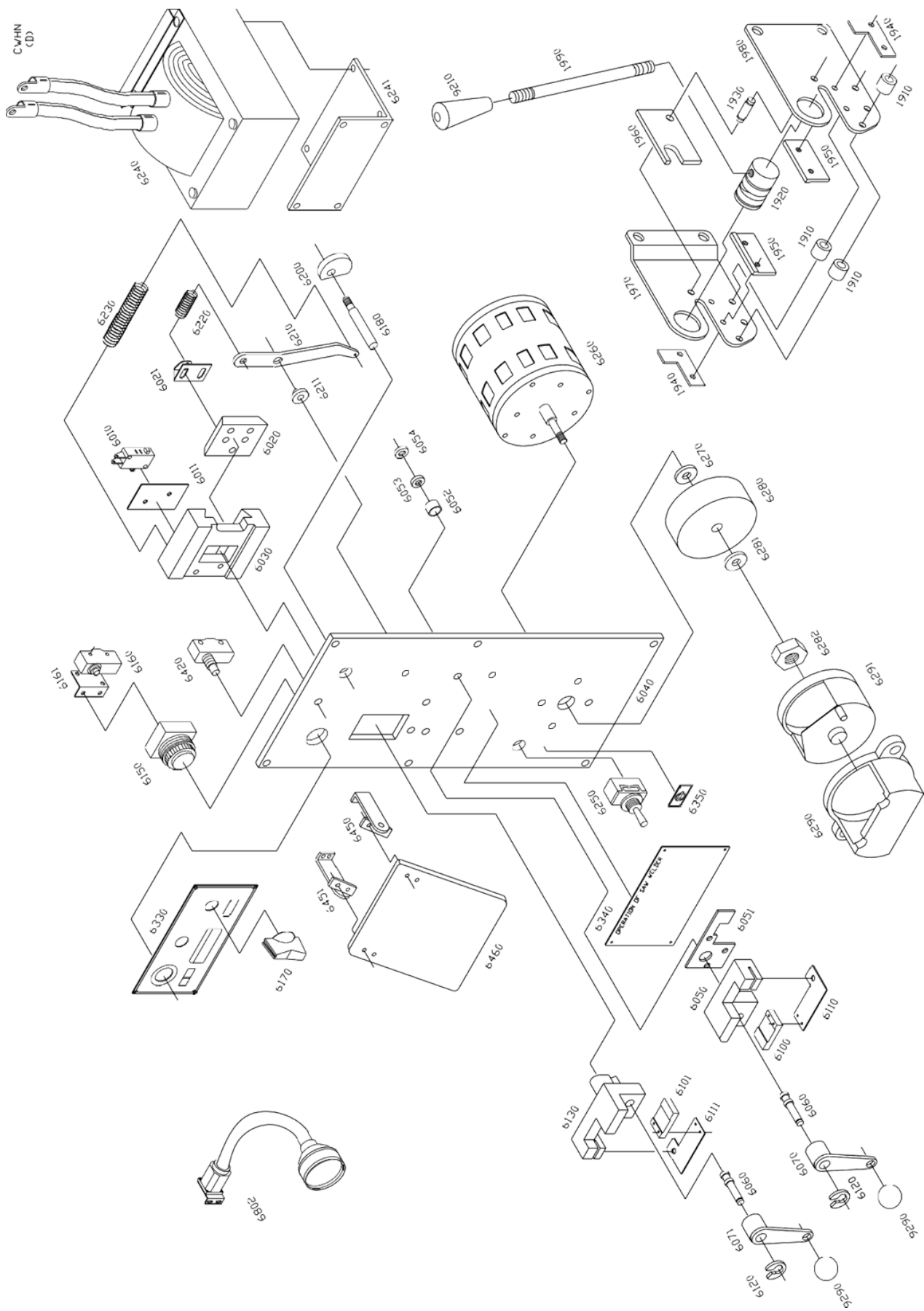

WELDER COMPONENT

6010V26	1 *	LIMIT SWITCH 303250
6011V26	1 *	INSULATOR
6020V26	1 *	GUIDE BLOCK
6040V26	1 *	HOUSING
6050V26	1 *	STATIONARY JAW
6051V26	1 *	INSULATOR
6052V26	3 *	INSULATING TUBE
6053V26	3 *	WASHER, INSULATE
6054V26	3 *	SPACER
6060V26	2 *	ECCENTRIC SHAFT
6070V26	1 *	CLAMP LEVER, RIGHT
6071V26	1 *	CLAMP LEVER, LEFT
6100V26	1 *	CLAMP SUPPORT, RIGHT
6101V26	1 *	CLAMP SUPPORT, LEFT
6110V26	1 *	CLAMP PLATE, RIGHT
6111V26	1 *	CLAMP PLATE, LEFT
6111V26	1 *	CLAMP PLATE, LEFT
6120V26	2 *	CAM
6130V26	1 *	MOVING JAW
6150V26	1 *	WELD BUTTON 303271
6160V26	1 *	MICRO SWITCH
6161V26	1 *	MICRO SWITCH BRACKET
6170V26	1 *	PRESSURE ADJUST KNOB
6180V26	1 *	SHAFT
6200V26	1 *	CAM
6210V26	1 *	WELD TENSION ARM
6211V26	1 *	BUSHING
6220V26	1 *	SPRING, SHORTER
6230V26	1 *	SPRING, LONGER
6240V26	1 *	TRANSFORMER (4.2KVA)
6241V26	1 *	MOUNTING BRACKET (4.2KVA ONLY)
6250V26	1 *	SWITCH
303787	1 *	GRINDER MOTOR
6270V26	1 *	SPACER
6280V26	1 *	GRINDER WHEEL 303248
6281V26	1 *	1/4" WASHER, FLAT
6282V26	1 *	6 mm-1.0 HEX NUT
6290V26	1 *	GRINDER GUARD 303247
6291V26	1 *	GRINDER COVER 303246
6330V26	1 *	WELDER NAME PLATE
6340V26	1 *	INSTRUCTION LABEL
6350V26	1 *	GRINDER LABEL
6420V26	1 *	ANNEAL BUTTON 303231
6450V26	1 *	DEFLECTOR BRACKET, RIGHT
6451V26	1 *	DEFLECTOR BRACKET, LEFT
6460V26	1 *	SPARK DEFLECTOR
9290V26	2 *	KNOB 303249
WCPV26	1	42-WELDER ASSEMBLY

WORK LAMP COMPONENT

6802V26	1 *	WORK LAMP COMPONENT 303272 Bulb MR 16 12v 20W
---------	-----	--

SHEAR COMPONENT

1910V26	3 *	SPINDLE BUSHING
1920V26	1 *	SPINDLE LIFT
1930V26	1 *	BLADE SHAFT
1940V26	2 *	VANED IRON PLATE
1950V26	2 *	LOWER BLADE
1960V26	1 *	UPPER BLADE
1970V26	1 *	JOINT PLATE, LEFT
1980V26	1 *	CHAIN JOINT, RIGHT
1990V26	1 *	HANDLE BAR
9210V26	1 *	KNOB
SCPV26	1	SHEAR COMPLETE 303234

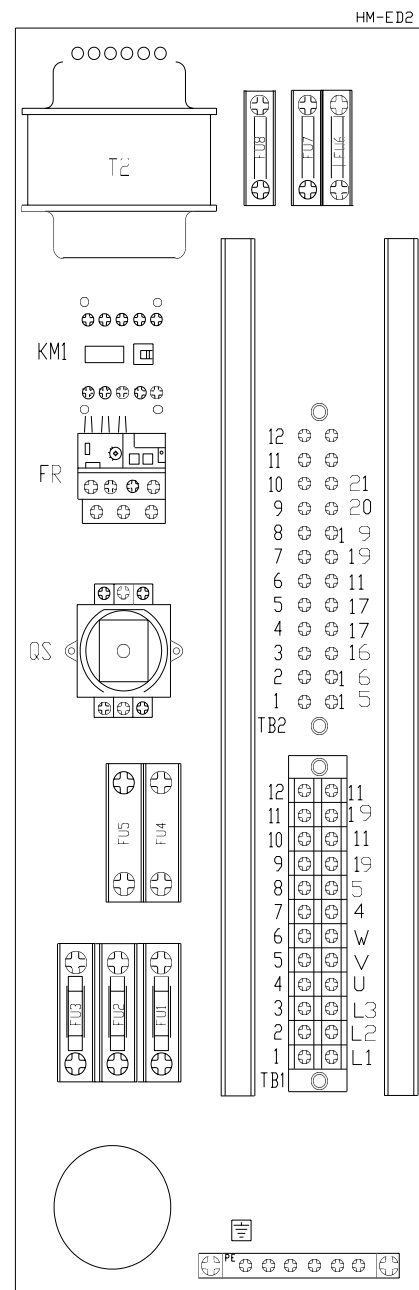

AC 3Ø 230/460V

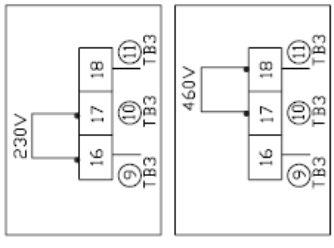
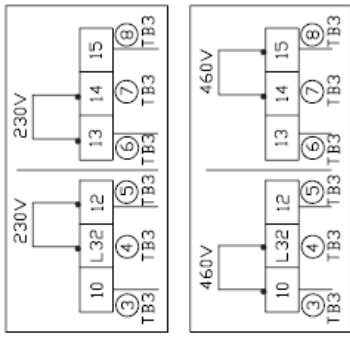
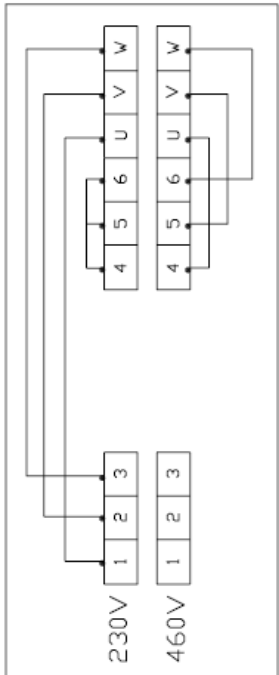
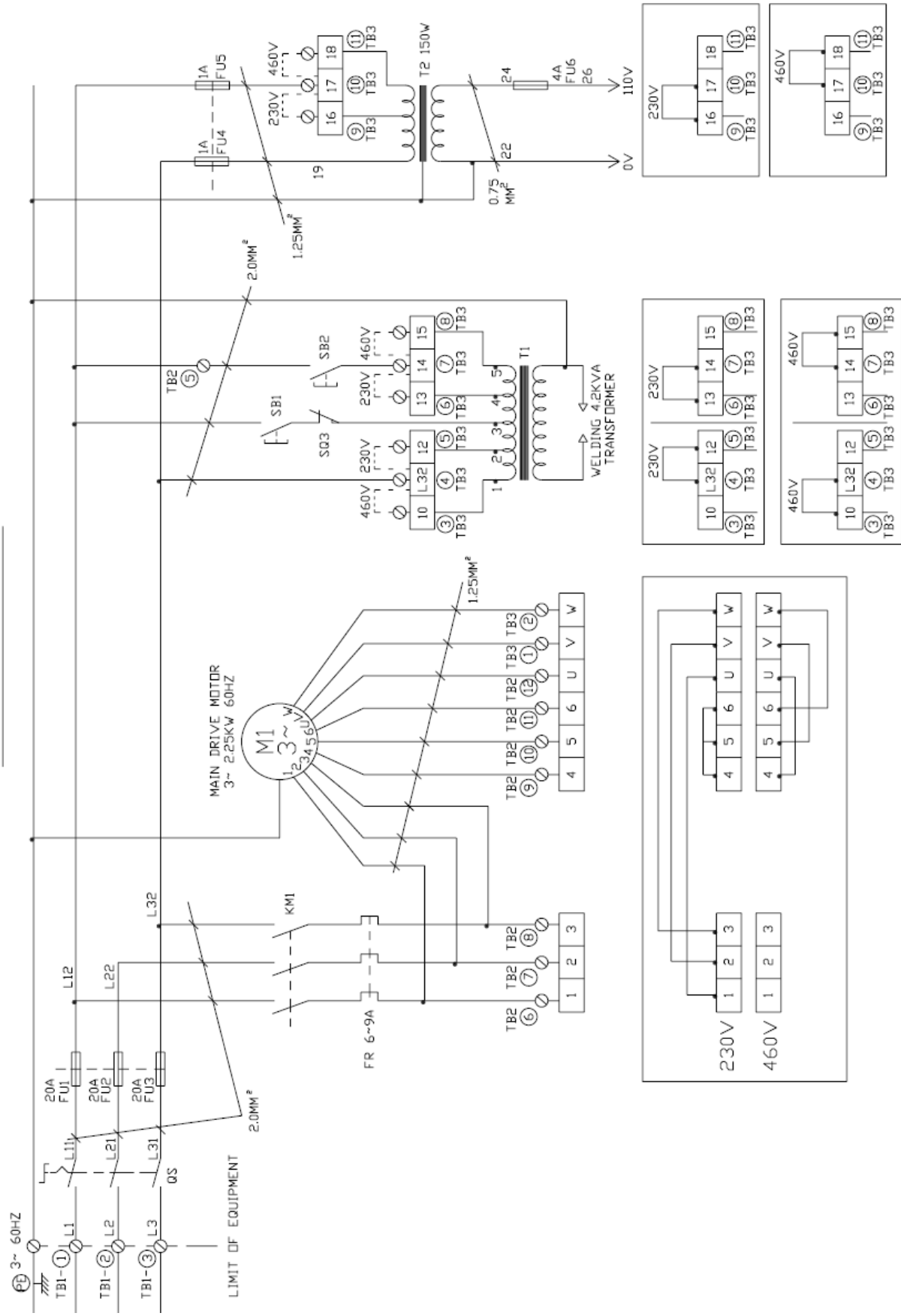

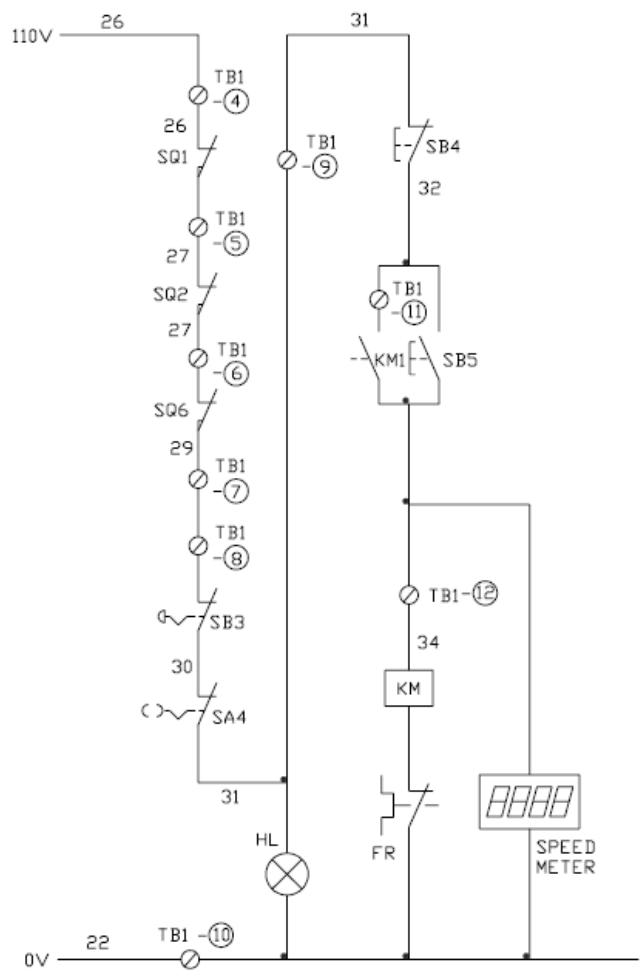
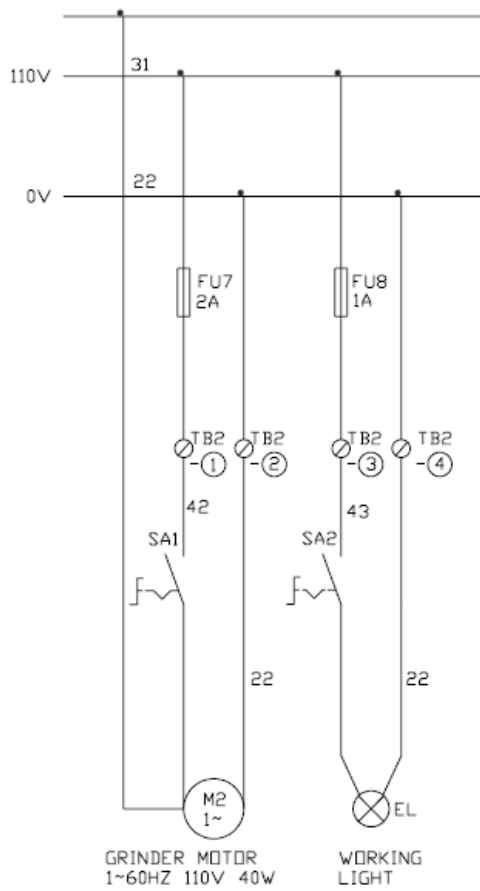

SB1	WELD ON	WHITE	SA4	KEY SWITCH	SQ6	SAFETY SWITCH	36*TYPE ONLY
SB2	ANNEAL ON	GREEN	HL	INDICTOR LIGHT	KM1	CONTACTOR	
SB3	EMERGENCY STOP	RED	EL	LAMP 60W, 115V	FR	OVERLOAD RELAY	
SB4	MAIN MOTOR OFF	RED	QS	MAIN SWITCH	T1	TRANSFORMER	
SB5	MAIN MOTOR ON	GREEN	SQ1	SAFETY SWITCH	T2	TRANSFORMER	
SA1	GRINDER MOTOR ON		SQ2	SAFETY SWITCH	QS	MAIN SWITCH	
SA2	WORK LAMP ON	BLACK	SQ3	WELD AUTO STOP	FU	FUSE	

Warnings

- Employer is responsible to perform a hazard/PPE assessment before work activity.
- Do not make repairs or adjustments unless you are competent or working under competent supervision.
If in doubt consult a qualified technician or engineer
- Only use Dake original parts
- Do not alter this band saw from the original design.
- Lock out Tag out procedures must be followed by authorized employees as per OSHA.

ELECTRIC – Electric must be locked out in accordance to OSHA standards.

WARNING LABELS



To the left is the safety Alert symbol. When you see these safety alert symbols on your band saw, be alert to the potential for personal injury.

Follow recommended precautions and safe operating practices.

Carefully read all safety messages in these instructions and on your band saw safety signs. Keep safety labels in good condition. Replace missing or damaged safety labels. **This machine is intended to be operated by one person.**



Label 84604



Label 84605

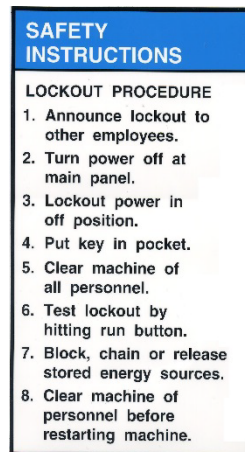

Label 76462



76462
on side
of
machine



This machine is wired for 220
volt 3 phase!



Circle Cutting Attachment

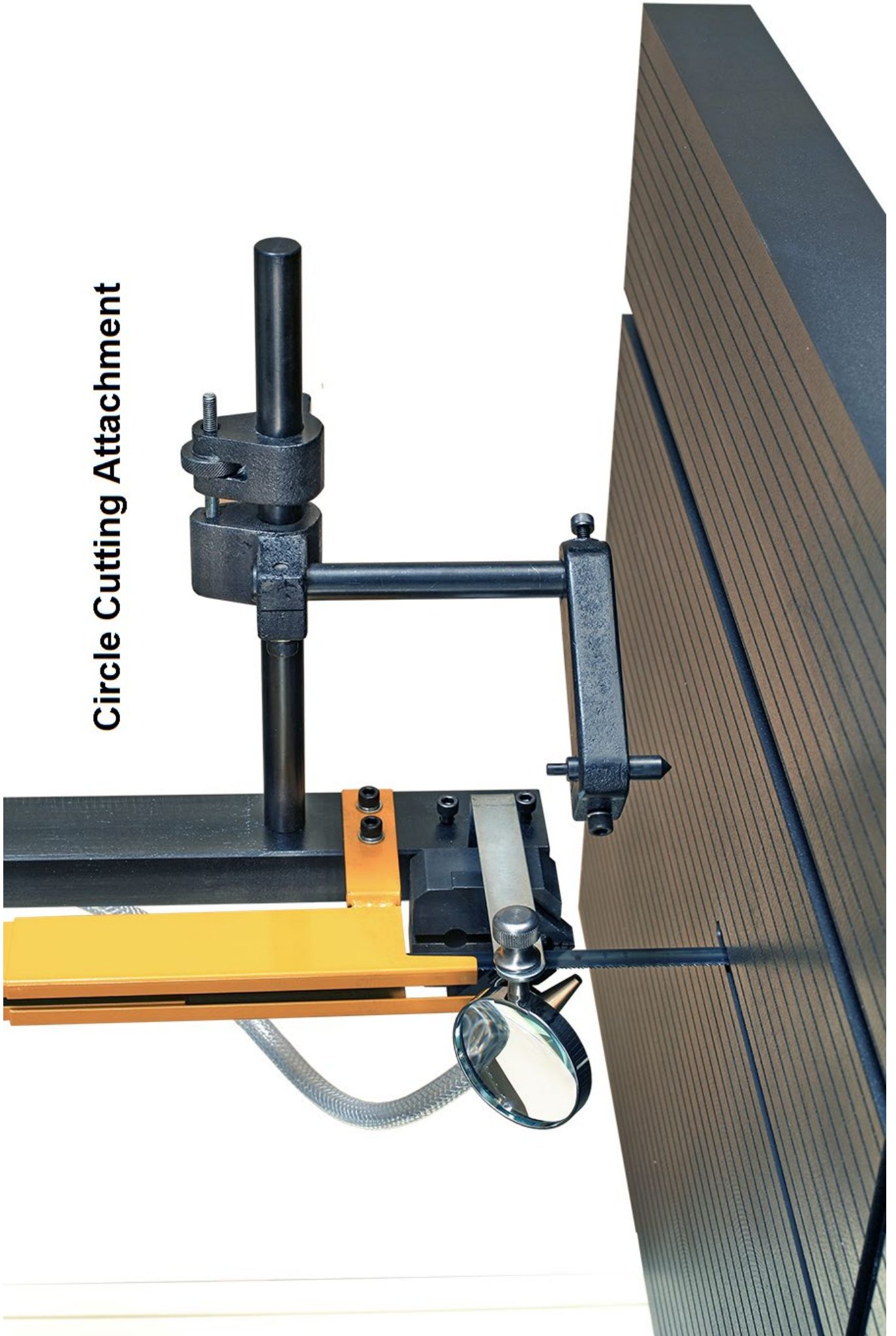

CIRCULAR CUTTING ATTACHMENT:

1. Install the Circular Cutting Attachment. <Figure 1>
2. A. The position of the blade tooth should be opposite to the cutting center at nine o'clock position. <Figure 2>
 - B. The height between the object and the blade guide end is suggested to be about 5 mm. <Figure 3>
 - C. Use the blade under 8mm width if possible, it will avoid interference. When cut smaller circle, use smaller width blade.
3. A. Measure the cutting radius, set the distance between the blade tooth and the Set Point by the Lock Screws. Loosen the Lock Screw (1) & (2) to adjust the cutting radius. Tighten the Lock Screw (1) & (2) after finish it. <Figure 1, 4 & 6>
 - B. Use the Micro Adjust Screw to get the precise cutting radius. Loosen the Lock Screw (1), and then adjust the Micro Adjust Screw. Tighten the Lock Screw (1) after finish it. <Figure 1 & 4>
4. Mark a center point (or drill 5mm hole) and draw a circle on the object. Start to cut from the object nearby until touch the rim, and then fix the Set Point in the object. < Figure 5 & 6 >
5. Rotate the object to finish it. <Figure 6>

