

FR-55 Scissor Frame Rack Machine

The FR-55 Scissor Lift & Frame Rack is a unique, high quality, compact frame straightening machine with the versatility of an automotive lift, designed to service Full-frame or Uni-body type vehicles with its 5,500 lb. lifting capacity. The FR-55 incorporates a 10 Ton 'multi-angle/adjustable height' Pull Tower with 360 degree pulling capability, along with adjustable height Clamping assemblies and universal positioning Swivel Arms & Lift Pads. The FR-55 also comes standard with Pull Chain with Hook and Wheel Stands.



FR-55
Scissor
Frame Rack
Machine

Wheel Stands Included



Portable Console Cabinet with
Remote 'hand held' Pendant

10 Ton Pull Tower w/ Multi-Angle
360 degree Pulling Capability

Adjustable height Pinch Weld /
Clamp Assemblies & Lift Pads

FR-55 - Scissor, Frame Rack, 1P10T-5.5K (Detailed Features)

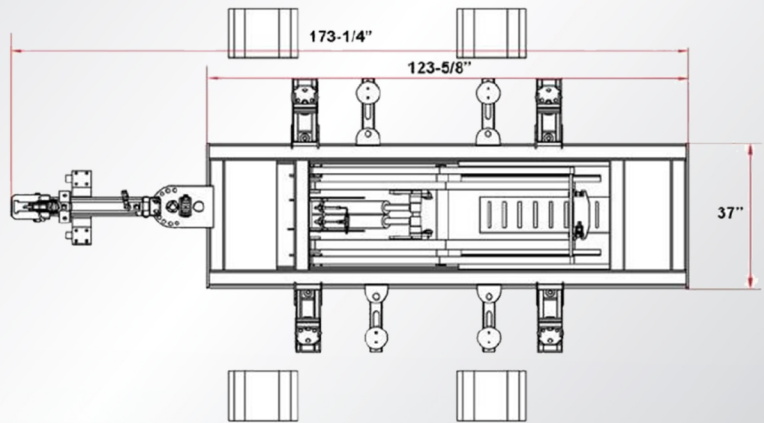
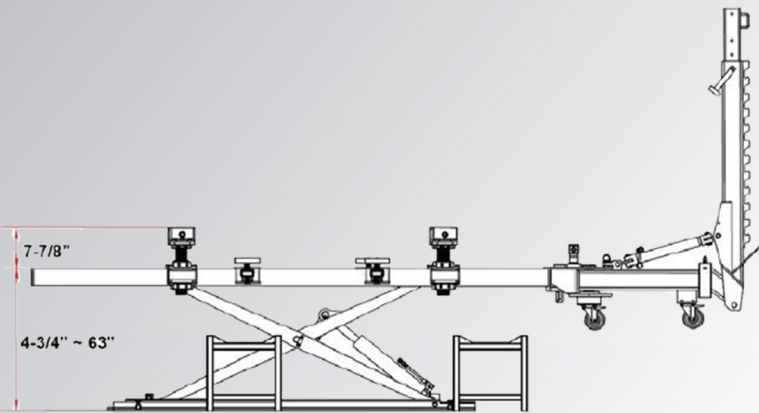

FR-55-TBK20
*Tool Board, Tool
and Clamp Kit
Sold Separately*

Features

• Lifting Capacity	5,500 lbs.
• Overall Length	173.25" (4401mm)
• Deck Length	123.62" (3140mm)
• Deck Width	37" (940mm)
• Deck Heights	4.75" to 63" (120mm - 1600mm)
• Tower Pull Force	10 Ton (100KN)
• Tower Air/Hydraulic Max Pressure	10,000 PSI (70MPa)
• Required Air Power	100 - 120 PSI (0.6 - 0.8 MPa)
• Console Electrical Power	220VAC - 20 Amp, 1 PH
• Ship Weight	3,105 lbs.
• Package Size	125"L x 38"W x 58"H

Specifications

- Designed to service Full-frame or Uni-body type vehicles
- Unique, Compact & Versatile design
- Scissor Lift operation with Twin Hydraulic Cylinders
- Durable, Heavy Duty construction with Powder Coat finish
- Portable Console Cabinet for Lift operation with Single Point Pneumatic Lock Release
- Remote 'hand held' Pendant for Lift operation
- Universal positioning Swivel Arms & Lift Pads
- 10 Ton 'slotted / adjustable height' Pull Tower with integrated Down Pull Roller
- Multi-Angle, 360 degree Pulling Capability
- Adjustable height Pinch Weld / Clamp Assemblies
- Quick Disconnect Hydraulic Fitting & Hose connection
- (1ea) HQ Air/Hydraulic Pump with Pressure Gauge
- (1ea) Pull Chain w/ Hook
- (4ea) Wheel Stands