

Challenger Lifts

INNOVATIVE LIFTING SOLUTIONS



Model#: EV1020

EnviroLift® in-ground cassette lift
10,000 lb. lifting capacity



EnviroLift® Electric Hydraulic Inground Lifts

Challenger's electric hydraulic cassette style in-ground EnviroLift® meets the rigorous demands of professional service facilities. With over 50% more bearing contact surface than competitor's lifts, enhanced wipers both top and bottom and larger 8-1/2" chrome pistons, your shop will have a superior, more stable and repeatable lift resulting in increased productivity. These in-ground lifts also eliminate environmental concerns with a fully contained polymer housing made from recycled plastic.

EnviroLifts require less shop space than surface mounted lifts. With a smaller footprint, your shop will maximize the number of service bays, resulting in higher parts and service revenue. EnviroLift® also creates a professional showroom style appearance with its open, aesthetically pleasing look.

Other standard features include a mechanical locking ladder that engages every 3" and a stainless steel air lock release cylinder to prevent rust associated with condensation. Available in 10,000, 12,000 and the exclusive 15,000 lb. lift capacity.

Features-&Benefits

Chrome Benefits

- Extends life of pistons
- Highly lubricous
- Ultra hard - harder than steel
- Stands up to high stress contact
- 100 times better wear than steel
- Less prone to abrasion
- Attractive finish
- Low friction

Over 50% more bearing spread than other competitive models, providing smooth and stable lifting up to 15,000 lbs.

Enclosed arm tube enhances structural integrity under maximum loading and reduces sharp edges

- Larger 8 1/2" diameter chrome pistons provides greater stability under load
- Chrome non-breathing ram style cylinder (EV1020 only) minimizes water intake and other contamination
- Enhanced raised wiper at top and bottom of bearing provides better grease retention and minimizes contaminants from entering into bearings
- Over 50% longer bearing contact than competitor lifts provides increased stability
- Mechanical lock engages every 3" provides safety and allows technician to work at their ergonomic height to increase productivity and minimize fatigue
- Stainless Steel air lock release cylinder promotes longer working life with its corrosion resistant design
- Fully contained and sealed recycled polymer cassette tub eliminates risk of hydraulic fluid seeping into the ground
- Double telescoping screw adjusts from 3-7/8" to 6" with removable rubber pad for frame contact (EV1020 only)
- Wide drive-thru at 87" accommodates wider vehicles, minimizes tire pinching and provides easy drive-on (EV1020 and EV1220 only)

A simple way to increase the rise and descent speed of your Challenger Lifts!



How do we achieve accelerated lifting?

We have increased the motor and pump size which provides a faster rise and descent. These components increase the rise of speed from 48 seconds to **27 seconds** equating to a 42% time savings.

Lowering speed is held to a constant **17 seconds** (approximately) regardless of the weight of the vehicle.

2X
FASTER than standard models



Increasing revenue potential just got **FASTER!**

up in **27** sec.

down in **17** sec.
regardless of vehicle weight

Lifting Point Configurations



EV1020

3-stage front and 3-stage rear swing arms or drive-on fixed pad with 2-way directional sliders and (4) 4-1/8" multi-position rubber spotting blocks.



EV1220

2-stage front and rear swing arms with standard combination stack screw pads to accommodate a wide range of heavier vehicle lift points.



EV1520 – EXCLUSIVE

Heavy-Duty 2-stage drive-over front and rear swing arms and standard combination stack screw pads accommodate a wide range of heavier vehicle lift points.

Optional StayDry

Pneumatically powered from the existing air supply. StayDry automatically removes any accumulated condensate from the floor of the lift containment system each time the lift is lowered.

Part#: SD100



Universal Prekits

For 10,000, 12,000 and 15,000 lb. capacity inground cassette lifts. Supports future growth and eliminates costly and unsightly floor excavation.

Part#: CSPK



EV1220 & EV1520 standard features:



EV1020MP9

Designed for high volume quick service. This lift features an adjustable drive-on pad design enhanced with low profile drive over clearance.

Two-way adjustable sliders allow the pad to easily extend or retract for quick and accurate spotting. Optional tire hanger kit also available.

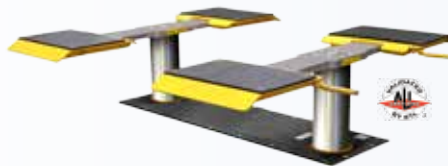

Standard Adapters:



63100

Shown with optional Tire Hanger Kit.

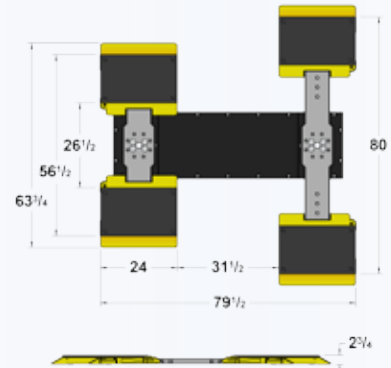

Power Control Configurations



Bench Mount Power Controls

Optional bench mounted power controls include raise, lower and lock release functions. They are aesthetically pleasing and mount to many major workbench brands, providing convenient access to inground lift controls.



Standard Power Controls

Standard power control unit mounts to walls near workbenches. Features single push button lift function and down release valve handle.

Model Number	EV1020	EV1020-QC	EV1220	EV1520
Lifting Capacity	10,000 lb. (4536kg)		12,000 lb. (5442kg)	15,000 lb. (6806kg)
Stroke	68" (1727mm)			
A Rise Height ¹	74" (1880mm)		81 ¹ / ₄ " (2064mm)	84 ³ / ₄ " (2153mm)
B Width Overall	110" (2794mm)		99" (2515mm)	71 ¹ / ₂ " (1816mm)
C Drive-Thru Clearance	87" (2210mm)			NA
D Reach (Arm Minimum)	19 ⁵ / ₈ " (498mm)		32" (813mm)	26 ¹ / ₄ " (667mm)
E Reach (Arm Maximum)	42 ¹ / ₈ " (1070mm)		49 ¹ / ₄ " (1251mm)	43" (1092mm)
F Rubber Pad Adapter	3 ⁷ / ₈ " - 6" (98mm - 152mm)		5" - 7 ¹ / ₄ " (127mm - 184mm)	6 ¹ / ₂ " - 8 ³ / ₄ " (165mm - 210mm)
G Adj. Adapter Height ² (with Medium Extensions)	6 ⁷ / ₈ " - 9" (175mm - 229mm)		8" - 10 ¹ / ₄ " (203mm - 260mm)	10 ¹ / ₂ " - 12 ³ / ₄ " (267mm - 324mm)
H Adj. Adapter Height ² (with High Extensions)	9 ⁷ / ₈ " - 12" (251mm - 305mm)		11" - 13 ¹ / ₄ " (289mm - 337mm)	14 ¹ / ₂ " - 16 ³ / ₄ " (368mm - 425mm)
Capacity (Per Arm)	2,500 lb. (1134kg)		3,000 lb. (1361kg)	3,750 lb. (1701kg)
Guide Plunger Diameter	8 ¹ / ₂ " (216mm)			
Motor	2HP			
Voltage (Single Phase Std.) ³	208v - 230v			
Speed of Rise	40 Seconds	27 Seconds	48 Seconds	60 Seconds
Air Required	75 - 125 psi			
Recommended Ceiling Height (plus height of tallest vehicle)	79" (2007mm)		82" (2083mm)	85" (2159mm)

¹ Rise height is measured with superstructure in highest position. ² Medium and high stack adapter extensions are standard with EV1220 and EV1520, optional with EV1020. ³ Optional 3 phase power unit also available, please specify at time of order. † Frame engaging adapters (**10314** or **10318**) are REQUIRED when lifting vehicles with frame construction.

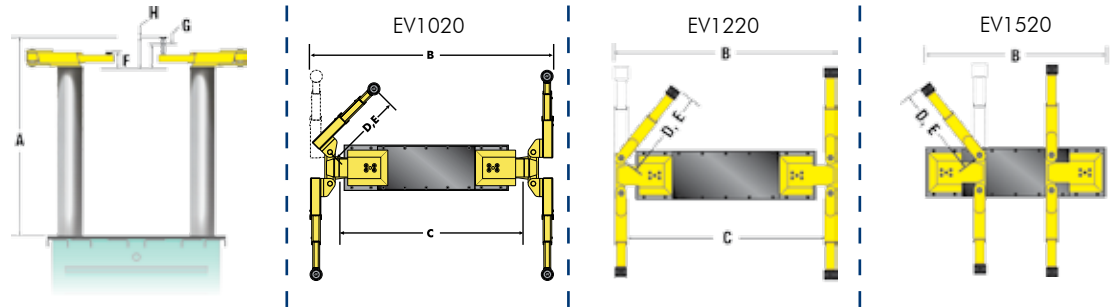

Smaller Footprint = More Money

11 inground lifts fit in the same space as 10 above ground lifts. With each service bay worth over \$200,000 in annual parts and service sales, more service bays mean more money.

We can provide detailed CAD layouts to ensure the best balanced layout for your shop including:

- » Proper selection of vehicle lifts, air compressor systems and other shop equipment
- » Lift layout for maximum space utilization, aesthetics and parts and service productivity
- » Vehicle traffic flow analysis



For more information, contact your Authorized Challenger Lifts Distributor:



The Automotive Lift Institute (ALI) certifies that the EV1020, EV1220 & EV1520 described herein comply with the applicable provisions of the American National Standards ANSI/ALI ALCTV 2011 and are Third Party Validated by the ETL Testing Laboratory.

CHALLENGER LIFTS, INC.
200 Cabel Street
Louisville, Kentucky 40206

Phone Toll-Free: 800-648-5438
502-625-0700

Fax: 502-625-0711

E-mail: sales@challengelifts.com

Challenger Lifts, Inc. reserves the right to make changes to specifications without notice and without making changes retroactive. Unloading, installation and oil not included.