



MC655R HYDRAULIC LIFT MANUAL



K&L SUPPLY CO., INC
2099 S. 10th St Unit 80, San Jose CA, 95112
TEL: 1-800-727-6767 FAX: 1-408-727-4842
Website: www.klsupply.com

K&L SUPPLY CO., INC developed this document for its Licensees and customers.
The information contained herein is the property of K&L SUPPLY CO., INC and may not be copied, used, or disclosed to others without prior written approval from K&L SUPPLY CO., INC
Users are cautioned that the material contained herein is subject to change by K&L SUPPLY CO., INC at anytime and without prior notice.

NOTE TO THE USER

Thank you for purchasing this MOTORCYCLE LIFT.
Please read these instructions carefully for safe and proper use of the lift, and keep for future reference.

This Manual is for MC655R HYDRAULIC LIFT

1. READ MANUAL FOR ASSURANCE OF SAFETY IN DESIGN AND CONSTRUCTION OF LIFT.
2. PLEASE MAKE SURE THAT THIS MANUAL IS DELIVERED TO END USERS TO ENSURE PROPER OPERATION OF LIFT.
3. DO NOT USE THE MOTORCYCLE LIFT IN A POTENTIALLY EXPLOSIVE ATMOSPHERE

- NO PART OF THIS MANUAL MAY BE REPRODUCED IN ANY FORM WITHOUT PERMISSION OF K&L SUPPLY CO, INC..
- THIS PRINT IS SUBJECT TO CHANGE WITHOUT NOTICE.

Copyright (C) K&L SUPPLY CO., INC

WARRANTY

The warranty period of the Motorcycle Lift shall be for a period of one year from the date of delivery to sales agent.

Subject to the limitations set forth below,

Contractor warrants that the Motorcycle Lift will be free from defects in material and workmanship and agree to, at part, including repaired or replaced parts, in the which they are (1) due solely to be defective material and/or poor workmanship on the part of contractor and/or its sub-contractors and (2) for which a 30 day notice given to the contractor in writing or by FAX. Please confirm in writing within (30) thirty days after discovery of any defects that will be claimed.

This warranty is subject to the following conditions:

- 1) Motorcycle Lift shall be properly used and operated by the company's operator solely in accordance with the specifications and operating instructions provided by contractor.
- 2) This warranty shall not be constructed to cover any defects due to;
 - Normal wear and tear;
 - Bad operation and maintenance not in accordance with the operating and maintenance manuals to be provided by contractor;
 - Operation under conditions other than those listed in the specification and drawings;
 - Change in design or other modification by company without contractor's consent;
 - Movement or transfer without contractor's consent;
 - Consumable items within normal operation;
 - Any other carelessness not attributable to contractor.

Contact your sales agent for warranty coverage.

K&L SUPPLY CO., INC

1040 Richard Ave, Santa Clara, CA, USA, 95050

TELEPHONE: 1-800-727-6767 FAX: 408-727-4842

TABLE OF CONTENTS

NOTE TO THE USER	S1
WARRANTY	S2
TABLE OF CONTENTS	S3
CHAPTER 1. SAFEGUARDS	
1-1 Important Notices	1-5
1-2 Qualified Personnel	1-6
1-3 Danger Notices	1-7
1-4 Principle Safety Objective.....	1-7
1-5 Safety Notices	1-8
1-6 Essential Safety Checks (ESC's)	1-13
1-7 Illumination	1-14
1-8 Level of Sound Pressure	1-14
1-9 Training	1-14
CHAPTER 2. OVERVIEW OF MACHINE	
2-1 Specifications	2-15
2-2 Diagram.....	2-16
2-3 Picture	2-17
CHAPTER 3. OPERATION	
3-1 Flowchart for OPERATION.....	3-18
CHAPTER 4. INSTRUCTION	
4-1 INSTRUCTION.....	4-19
CHAPTER 5. MAINTENANCE	
5-1 General caution during maintenance.....	5-21
5-2 Check List and periodic maintenance	5-22

APPENDIX

1-1 Spare Part List A-1

1-2 Spare Part List A-2

2 OPTIONAL EQUIPMENT A-3

CHAPTER 1. SAFEGUARDS

Please read this chapter carefully for safe and proper use of the motorcycle lift. K&L Supply Co. will not be held responsible for any injuries or accidents that occur due to the motorcycle lift being operated without having understood the contents of this instruction manual. Keep the Instruction Manual close to the motorcycle lift so that anyone can refer to it when necessary. Also, designate a person to take care of the manual.

1-1 Important Notices

A Motorcycle lift must be considered to be a potential hazard to the health and safety of the motorcycle lift's operator and service personnel. It is important that this motorcycle lift is installed, maintained, and operated according to the instructions set out within this manual. This is a responsibility imposed on the customer by the EU Council Directive 89/655/EEC, concerning the minimum safety and health requirements for the use of work equipment by workers at work.

Any modification, alteration or addition to the motorcycle lift or the fitting of ancillary equipment must comply with the EU Council Directive(s). K&L Supply does not accept any liability whatsoever, which may result in legal action from failure to comply with these regulations, or any consequential loss, claim or counter claim for damage, personal injury, or death arising as a result of any modification, alteration or addition to the motorcycle lift or the fitting of ancillary equipment.

EU Council Machinery Directive 98/37/EC

The above machinery directive requires all new machinery to carry the CE mark, declaring conformity with all relevant EN standards in respect of safety systems and motorcycle lift construction.

All K&L SUPPLY MACHINERY carries the CE mark and thus conforms to the EU Directives. Any modification to the motorcycle lift may invalidate the original CE certificate; therefore always refer to K&L SUPPLY CO., INC. as reassessment may be required.

This document provides the information required for the intended use of lifting a motorcycle. The documentation is written for technically qualified personnel such as engineers or maintenance specialists who have been

specially trained and who have the specialized knowledge required in the field of industrial machinery.

Knowledge of the safety instructions and warnings contained in this document and the appropriate application are prerequisites for safe installation as well as safety in operation and maintenance of the motorcycle lift as described.

Only qualified personnel who have the specialized knowledge that is necessary to correctly interpret the general guidelines relating to the safety instructions and warnings and implement them in each particular case.

For the sake of clarity, not all details of all versions of the product are described in these documents, nor can it cover all conceivable cases regarding installation, operation and maintenance. Should you require further information or face special problems that have not been dealt with sufficient detail in this document, please contact the manufacturer specified on cover page.

We would also point out that the contents of this product documentation should not become a part of or modify any prior or existing agreement, commitment or legal relationship. The purchase agreement contains the complete and exclusive obligations of K&L SUPPLY CO., INC. Any statements contained in this document do not create new warranties or restrict the existing warranty.

1-2 Qualified Personnel

Persons who are not qualified should not be allowed to operate the motorcycle lift. Non-compliance of the warnings contained in this document or appearing on the motorcycle lift can result in severe personal injury or damage to property.

Only qualified personnel should be allowed to work on this motorcycle lift.

Qualified persons as referred to in the safety precautions in this document as well as on the motorcycle lift itself are defined as follows:

- Operating personnel who have been trained to work with the motorcycle lift and are conversant with the contents of these documents are allowed to perform actual operation of lift;

- Service personnel who are trained to repair the motorcycle lift and who are authorized to energize, clear, ground, and tag circuits, equipment and systems in accordance with established safety practices.

1-3 Danger Notices

The safety precautions in this manual are classified into the following four levels. Please be particularly careful when performing operations that have a high degree of danger.

DANGER: Failure to follow this safety precaution may result in great physical danger to the operator, or even death.

CAUTION: Failure to follow this safety precaution may result in great physical danger to the operator, or severe damage to the motorcycle lift.

WARNING: Failure to follow this safety precaution may result in an injury to the operator, or damage to the motorcycle lift.

NOTICE: Failure to follow this safety precaution may result in damage to the motorcycle lift.

1-4 Principle Safety Objective

- 1) The principle safety objective is to remove the possibility of any hazard or risk to the health or safety of the lift's operator or service personnel.
- 2) Extreme caution must be exercised while servicing or installing the motorcycle lift.
- 3) The only safe policy when operating or inspecting this motorcycle lift is to follow the instructions in this manual. Wherever possible shut off all electrical power and follow the procedures outlined in this manual.
- 4) Accident prevention should become part of standard working, operating and maintenance procedures, and training should be provided to ensure

safety standards are understood. Part of safety training should include the instructions outlined in this section.

- 5) If ancillary equipment is to be fitted ensure this is done in accordance with the relevant standards or EU Directives, and that all requirements for safety are fully met.
- 6) Always ensure suitable qualified personnel carry out servicing and maintenance tasks. The operator should understand the limits of their responsibility, and the training should reinforce the importance of not exceeding them.
- 7) The essential safety checks (ESC's) serve an important function in ensuring the motorcycle lift continues to operate in a safe manner. These checks must be carried out according to the instructions and intervals covered in this manual.
- 8) If there are any questions or doubts regarding any aspect of motorcycle lift safety or operation or maintenance, please contact the company shown on the front of this manual.



1-5 Safety Notices

To protect the operator or service personnel from any injuries or accidents during operating the motorcycle lift, please read this section carefully for safe and proper use of the motorcycle lift.



⊙ General Safeguards







1. Only qualified personnel should be allowed to operate or service this motorcycle lift.
2. Prior to operation routine inspection should be carried out in accordance with the procedures described in the manual.
3. When abnormal conditions not specified in this instruction manual occur during operation, stop operation of the motorcycle lift and contact the manufacturer specified on cover page or distributor.
4. This lift is for motorcycle use only.

⊙ Danger Notices

	<p>Do not stand or sit under the motorcycle lift while lifting the motorcycle. This may result in physical danger or death.</p>
	<p>Maintain a safe distance from lift if there is a possibility of the motorcycle falling down. Failure to do so may result in physical danger or death.</p>

⊙ Caution Notices

	<p>Use the lift after carefully reading the instruction manual and understand the contents of them for safe and proper use of the motorcycle lift. If a user does not follow the warnings, a serious accident may occur</p>
	<p>When loading a motorcycle onto the lift, keep the motorcycle balanced and centered on lift. A motorcycle may fall during attachment or detachment of components.</p>
	<p>Electrical shock. When opening the control panel, be careful of electric shock. Serious injury or death may occur.</p>

	<p>Only qualified personnel should be allowed to operate or work on this motorcycle lift.</p> <p>Accidents may occur due to wrong operation.</p>
	<p>Do not attempt to keep lift raised by any other means than built in locking mechanism.</p> <p>The motorcycle may fall; resulting in physical danger or death.</p>
	<p>Do not shake motorcycle while operating lift.</p> <p>The motorcycle may fall; resulting in physical danger or death.</p>
	<p>Do not raise the lift with only one side of motorcycle the lift deck.</p> <p>Motorcycle may fall down or damage can occur. And also, the lift may be damaged.</p>
	<p>Never modify safety devices.</p> <p>If safety devices are not working, a serious accident may occur.</p>
	<p>While lowering the lift, be careful not to put your foot under the tabletop.</p> <p>Serious injury may occur.</p>

⊙ Warning Notice

WARNING

Use the lift after carefully reading the instruction manual and understand the contents of them for safe and proper use of the motorcycle lift.

< During preparation >

1. This Lift is for powersports vehicle use only (motorcycles, trikes, ATV's, UTV's, Golf Carts, etc.). Do not use for any other purpose.
2. Do not use the lift whenever any of the safety devices are not operating properly.
3. Be cautious and smooth when loading or removing vehicles from lift.
4. Be careful of footing when a tire, arm, or lift is wet.

< During lifting and lowering the lift >

5. Always watch the vehicle while operating lift to ensure that there are no problems taking place while raising or lowering.
6. If several lifts are installed, observe the location of the switch to be clear of any obstacles.
7. Do not lift a vehicle exceeding the rated capacity of the lift.
8. Do not lift a vehicle with persons or other load.
9. Check for oil or foreign material on the lift.
10. Only raise lift after verifying that vehicle is properly positioned.
11. Stop raising lift after it has reached maximum height.
12. When the lift raised or lowered, wait 1 or 2 seconds before the next operation is carried out.
13. Do not shake the vehicle during lifting and lowering of the lift. If the vehicle is settling to one side, stop the operation of the lift immediately.

WARNING

14. If the lift is not lowering in spite of pressing the down switch, raise the lift and then press the down switch again.
15. After the lift is completely lowered, the vehicle can be loaded or removed from the lift.
16. Prohibit unauthorized persons from standing near the lift while it is being raised and lowered.
17. Do not operate the lift with tools or components near the moving parts of the lift. Damage may occur to the lift and vehicle.
18. When lowering lift, make sure nothing will interfere with its descent.

< During vehicle repair >

19. Check if the safety lock device is working properly before operation.
20. Prohibit unauthorized persons from accessing the lift.
21. When the lift is not in use, or will not be in use for a long period, lower the lift completely.

< Other >

22. Do not change or modify the lift without permission. If the lift is modified or changed, the lift may not operate properly, or a serious accident may occur.
23. If you find a problem with the lift during use or inspection, stop operation and request maintenance from the sales agency. Do not use until the lift is repaired.
24. Please note that this lift is not designed to be waterproof. Do not use the lift in a hot environment, vehicle-washing or outdoor use.
25. Use the lift after reading the instruction manual carefully and understand the contents of them for safe and proper use.

1-6 Essential Safety Checks (ESC's)

The essential safety checks are the most important part of the operator's responsibility. The purpose of the ESC's is to ensure the safety features of the motorcycle lift are functioning properly, and thus the motorcycle lift is in a safe condition for use.

In addition to the operator it is recommended that a responsible person carry out regular additional ESC's and that a record is maintained in accordance with the EU machinery Regulations.

If any of the ESC's result in a "Fail" condition do not operate the motorcycle lift, immediately notify the responsible person within the company and contact the manufacturer as soon as possible.

ESSENTIAL SAFETY CHECKS (ESC'S)

GROUP 1 GENERAL - Visual Inspection

ESC	Description	O.K.	Fail
1A	Safety Lock Mechanism		
2B	Electrical system including protective earth grounding		

GROUP 2 Electrical isolator switches

Set the electrical isolator switch to OFF position and check the following conditions.

ESC	Description	O.K.	Fail
2A	All functions have been disabled		

1-7 Illumination

This machine does not provide local lighting since it is designed for indoor use only. The factory in accordance with the appropriate code of practice and factory regulations must fulfill sufficient illumination of the working area. Minimum 300 lx is required. Flicker, dazzling, shadows and stroboscopic effects must be avoided to prevent risk.

1-8 Level of Sound Pressure

The equivalent continuous A-weighted sound pressure levels of the motorcycle lift do not exceed 85dB (A).

	<p>The factory must provide operator(s) with the appropriate measures including but not limited to an ear protection and a warning sign(s) If the sound pressure WARNING of 85dB (A) is exceeded.</p>
---	---

1-9 Training

Contact the manufacturer specified on cover page for information on training courses to aid you in becoming familiar with this motorcycle lift.

CHAPTER 2. OVERVIEW OF MACHINE

2-1 Specifications

MC655R Hydraulic Lift	
Capacity	2,000 lbs (907kg)
Width	29.5 " (750 mm)
Length	86.5" (2,200 mm)
Maximum Height	48.5" (1,200 mm)
Minimum Height	7" (182mm)
Platform Thickness	0.128" (3.25 mm)
Weight	466 Lbs (211 kg)
Standard Motor	US Only : 115V 60Hz 13.5A 1690rpm / Condenser 300V/80uF Efficiency 51% International: 220V 50Hz 5.3A 1340rpm / Condenser 350V/80uF Efficiency 69%
Lifting Time	Approx: 20-30 Sec
Lowering Time	Approx: 30 Sec

2-2 Diagram

MC655R Hydraulic Lift

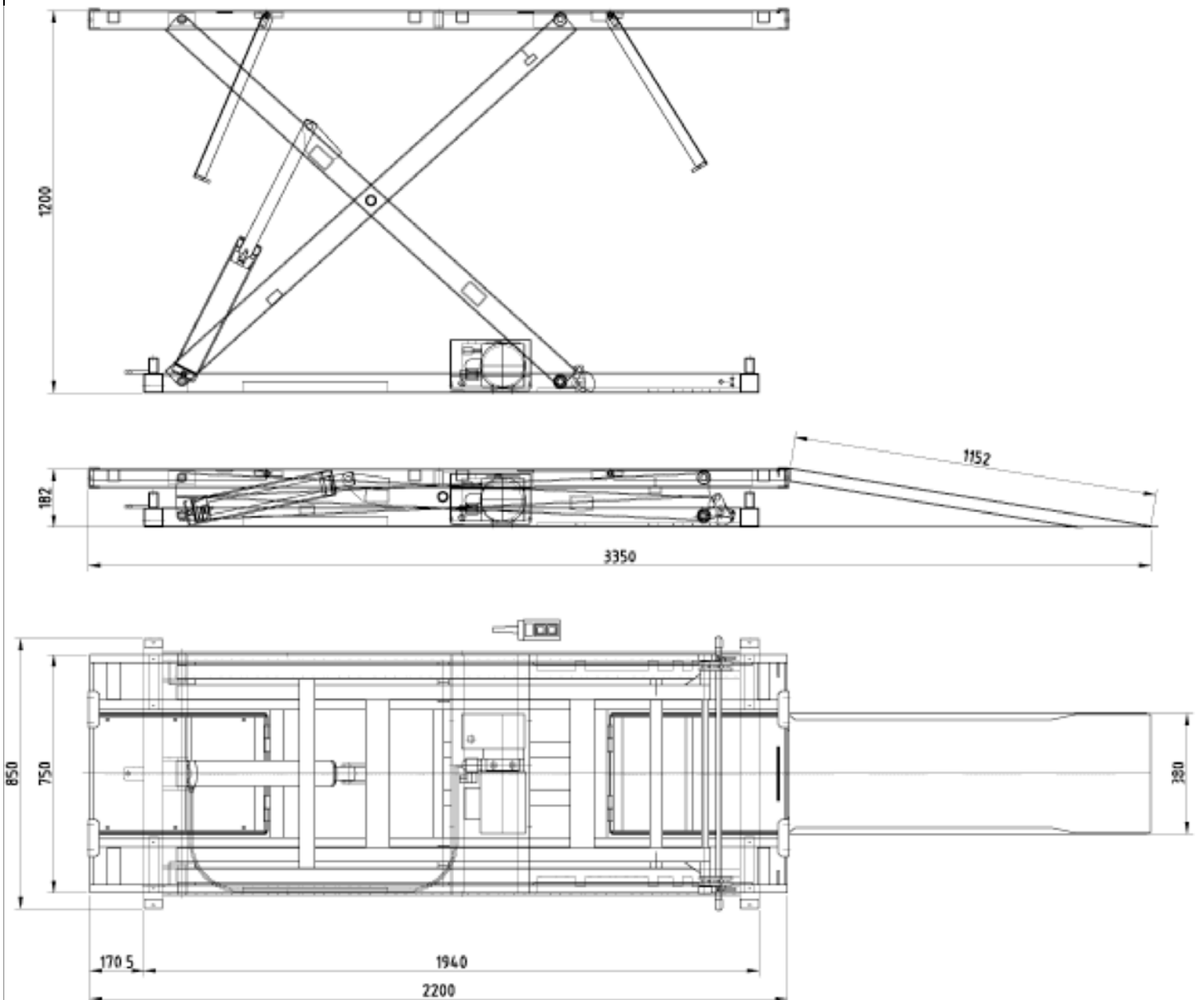

2-3 Picture

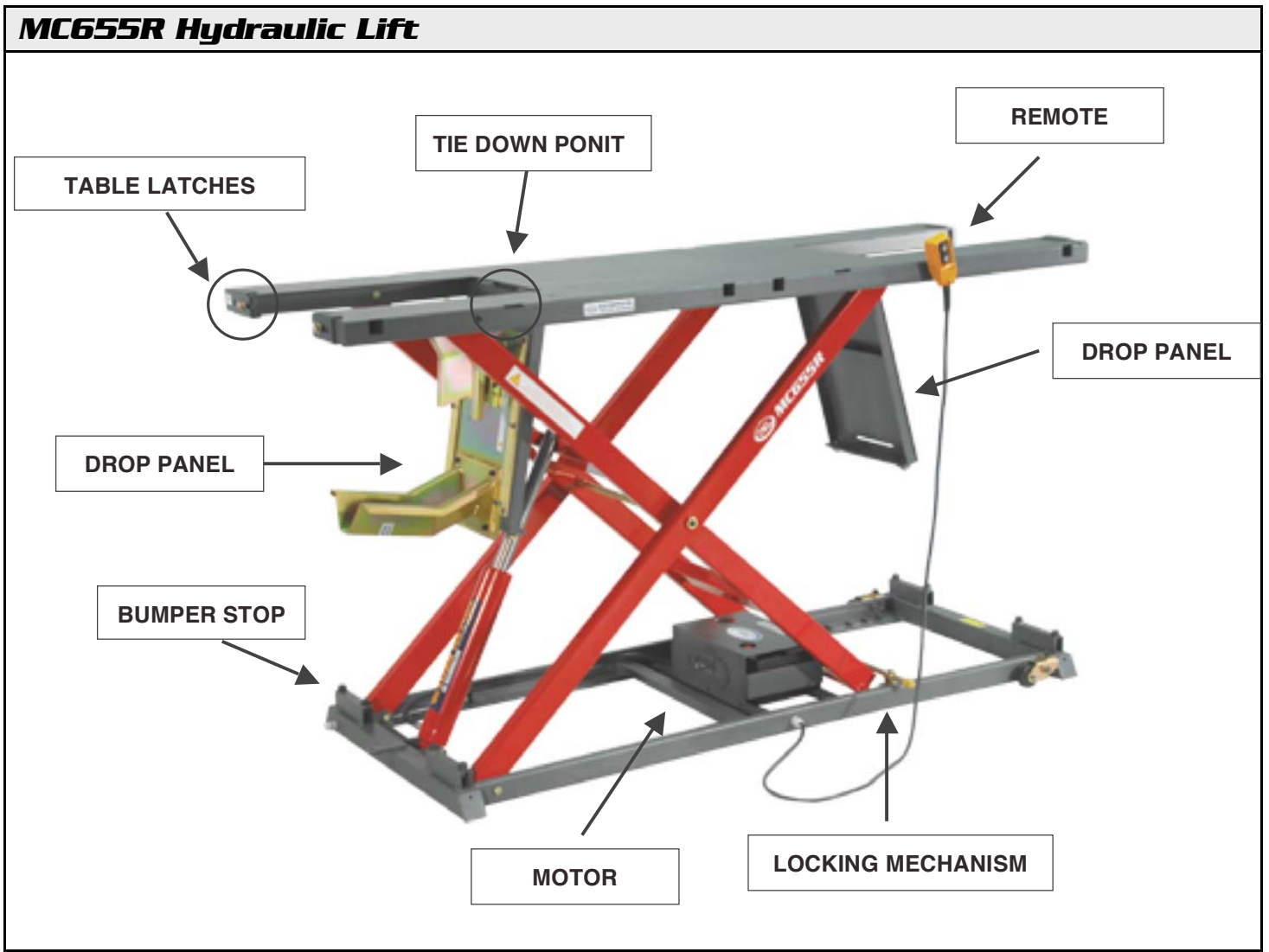

	<p>Motor Specifications</p>
<p>US Only : 115V 60Hz 13.5A 1690rpm Condenser 300V/80uF Efficiency 51%</p> <p>International: 220V 50Hz 5.3A 1340rpm Condenser 350V/80uF Efficiency 69%</p>	
	<p>Control Switch (REMOTE)</p>

CHAPTER 3. OPERATION

3-1 Flowchart for OPERATION

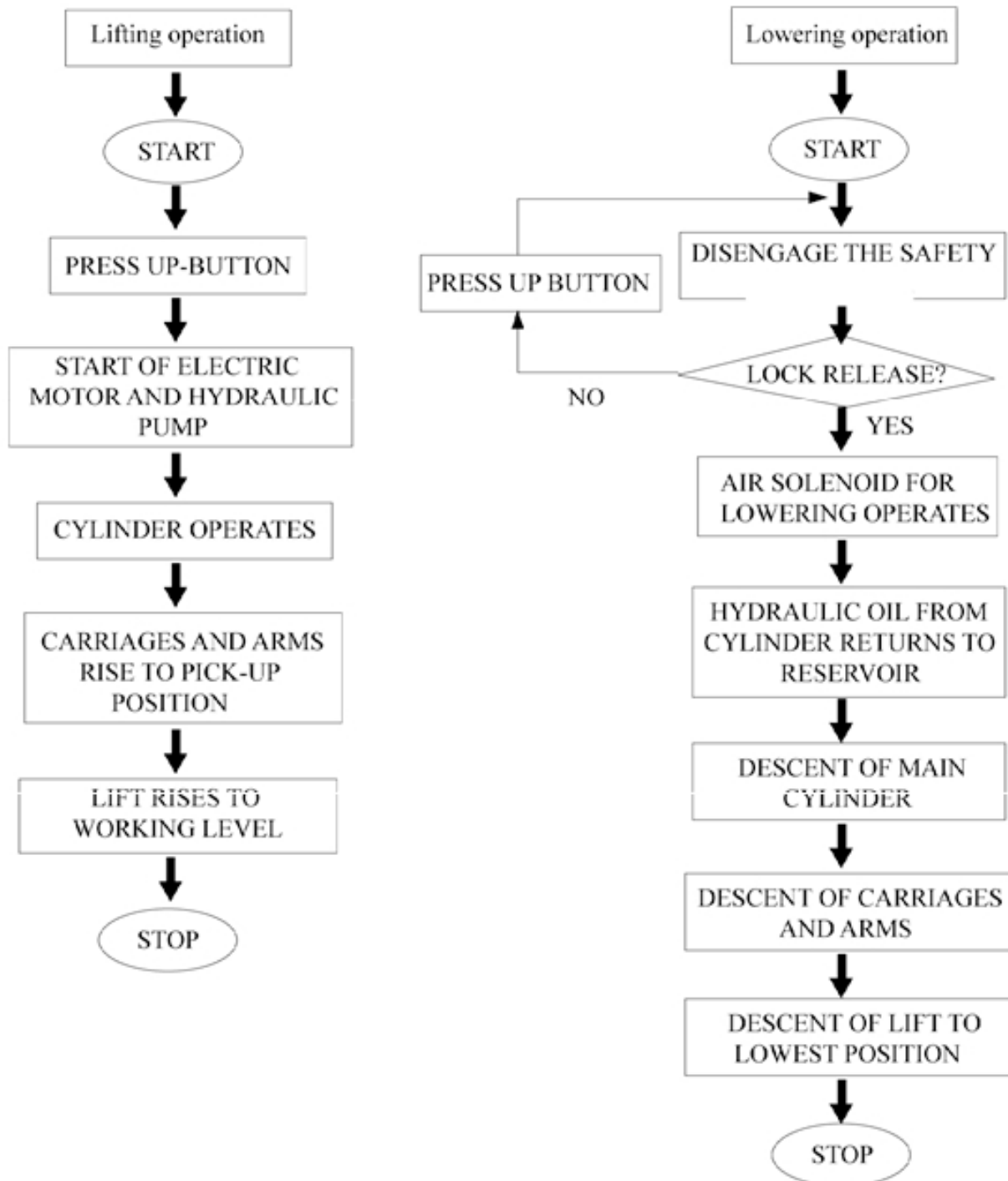

CHAPTER 4. INSTRUCTION

4-1 INSTRUCTION

Caution: As with all electrically powered equipment be aware of wet conditions and condition of the electrical cord to avoid electrocution. This product is intended for use by professionals in the performance of mechanical repairs on powersports vehicles and is to be considered dangerous if not maintained or if used improperly. Do not use an extension cord to power the hydraulic pump.

STEP 1. Check product and bill of materials to make certain all required parts are accounted for and in good condition.

STEP 2. Unit should be placed on a concrete surface free from as many defects as possible to prevent unit from tipping or rocking. Place unit in the area intended for use and adjust to make certain that unit is level and stable. Unit should be in close proximity to 110volt electrical outlet.

STEP 3. Prior to loading a motorcycle, the lift should be cycled 2-3 times to verify proper operation. Inspect remote control and determine if up and down buttons are functioning properly. Inspect pump for oil, open filler cap to add oil if needed.

STEP 4. Raise lift to comfortable working height (approx 35 inches) to make certain that drop down panels (front and rear) operate smoothly. Slide catches off of retention bolts and the panels will drop down, make certain to hold onto the panel and not let it fall freely.

Caution: Never operate lift while drop down panels are in the down position. Return them to the level position until the safety lock is set.

STEP 5. Loosely attach vice rails in the appropriate holes in deck of lift, slide vice into rails and make certain there is clearance to allow a smooth sliding motion. Tighten rails to deck and recheck sliding of clamp. Tighten pinch bolts to hold vice to deck of lift.

STEP 6. Attach ramp to rear of lift while in down position.

Caution: Do not leave ramp attached to lift while in operation or in up position.

STEP 7. Always use tie downs to secure vehicle to lift while operating.

STEP 8. If applicable, attach side extensions, as needed using the supplied hardware.

Caution: Do not leave ramps for the extensions attached while in operation or in the up position.

Notes: Be aware of all marked pinch points. Lubricate all points at least 3 times a year or more depending on frequency of use.

CHAPTER 5. MAINTENANCE

5-1 General caution during maintenance

- 1) Two or more persons should perform maintenance.
- 2) Maintenance should be carried out after putting a signboard of "NO ENTRANCE" at work area.
- 3) Do not disassemble the system before you are familiar with the disassembling sequence.
- 4) Record the place or parts where maintenance is needed.
- 5) Keep disassembled parts stored where they can be easily accessed.
- 6) Be sure to fasten bolts and nuts correctly in position during assembly.
- 7) During maintenance of control box, verify locks are in "engaged" position.
- 8) During replacement of electrical components, fasten the terminal bolts of part tightly after checking the wire no. (Or color) and parts no.
- 9) Clean inside control box with air once a month.
- 10) Check weekly for loose nuts and bolts, retighten if needed.
- 11) Do not open the control box without permission of authorized persons during maintenance.

5-2 Check List and periodic maintenance

Maintenance Interval Chart							
The following chart should be considered strictly as a guide to general maintenance intervals. Depending on operating conditions, the intervals of maintenance should be changed.							
Item \ Maintenance Interval		Initial			Thereafter Every		Part#
		10 hours	25 hours	50 hours	100 hours	200 hours	
		1 Month	3Months	6 Months	12Months	24Months	
Bolts	Inspect			X	X		601
Pivot Pin	Inspect		X		X		10, 11
Pivot Pin Circlip	Inspect, Replace			X	X		609, 610
Lubrication Points	Lubricate	X	X	X	X		
Drop Panels	Inspect			X	X		5A, 5B
Sliding Lock	Inspect			X	X		12R, 12L
Rollers	Inspect	X		X	X		8, 9
Cylinder	Inspect	X		X	X		7
Cylinder Seal	Visually Inspect	X		X	X		
Hydraulic Line	Inspect	X		X	X		
Hydraulic Pump	Inspect	X			X		20
Hydraulic Fluid	Replace					X *	
Electrical Cord	Inspect	X		X	X		
Remote	Inspect	X		X	X		22
Safety Lock Guide	Inspect	X	X	X	X		7
Locking Bar	Inspect	X	X	X	X		6

* AW38 Fluid Recommended (Substitute Dexron if AW38 is not available)

APPENDIX

1-1 Spare Part List

K&L MC655R Hydraulic Lift

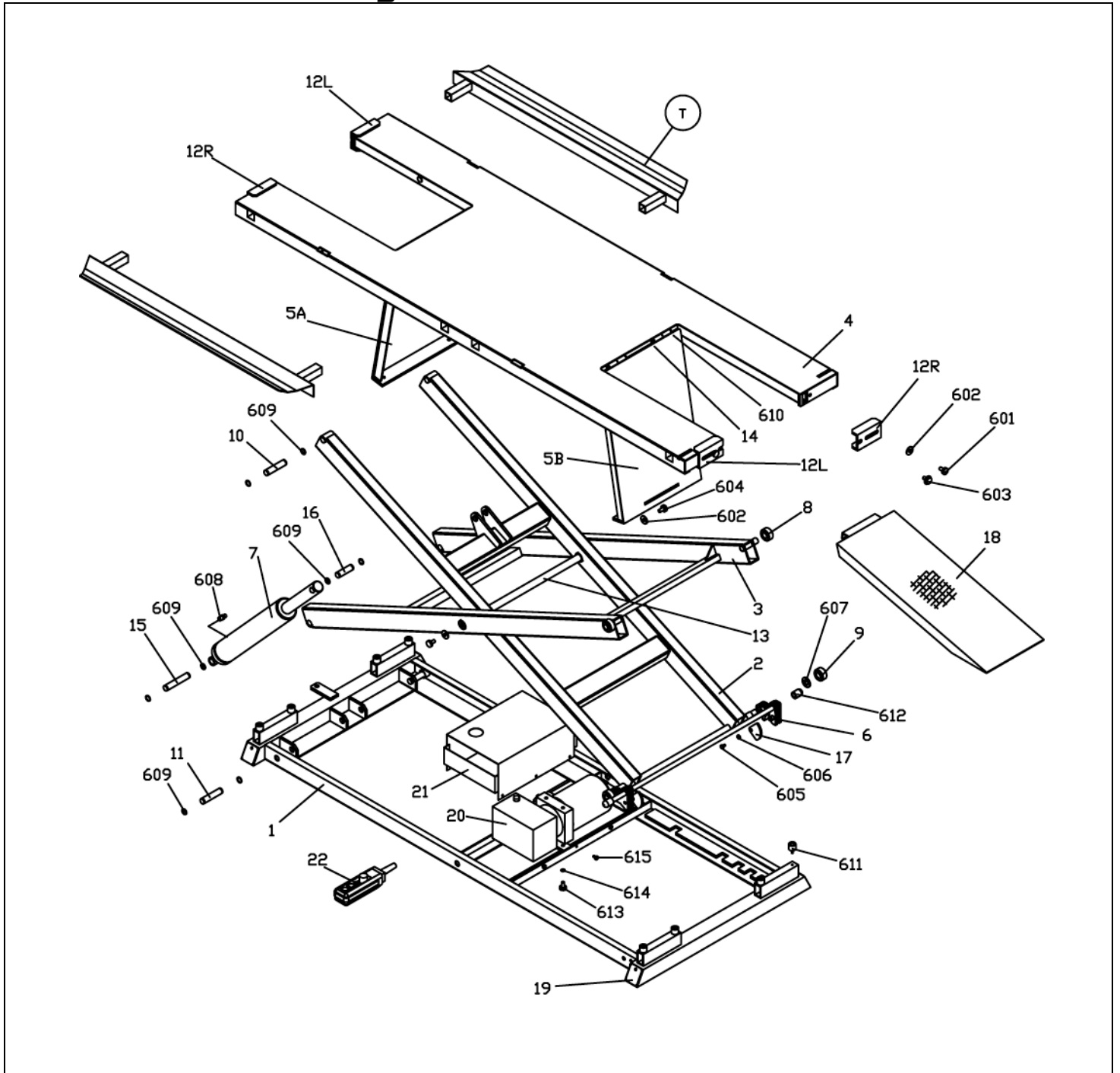

APPENDIX

1-2 Spare Part List

K&L SUPPLY CO., INC.

PART NO. 35-6564

NO.	DESCRIPTION	WEIGHT/SIZE	Q'TY/EA	NO.	DESCRIPTION	WEIGHT/SIZE	Q'TY/EA
1	LIFT BASE		1	20	HYDRAULIC POWER PACK		1
2	MAIN SUPPORT (A)		1	21	PUMP COVER		1
3	MAIN SUPPORT (B)		1	22	HAND SWITCH		1
4	TABLE TOP		1				
5A	FRONT DROP PLATE		1	601	SLIDE LOCK BOLT	M10 X 25	4
5B	REAR DROP PLATE		1	602	SLIDE LOCK FLAT WASHER	Ø10 X 30 X 3t	6
6	SAFETY LOCK ASSY		1	603	SLIDE LOCK FLANGE BOLT	M10 X 25	4
7	HYDRAULIC CYLINDER		1	604	ROUND HEAD ALLEN BOLT	M10 X 15	2
8	ROLLER - A	Ø43 X 24.5	2	605	ROUND HEAD ALLEN BOLT	M6 X 12	2
9	ROLLER - B	Ø43 X 21.5	2	606	FLAT WASHER	Ø6	2
10	PIN - A	Ø20 X 104	2	607	FLAT WASHER	Ø16 X 3t	2
11	PIN - B	Ø20 X 93	2	608	NIPPLE	PT1/4	1
12R	SLIDE LOCK (RIGHT)		2	609	CIRCLIP	S20	12
12L	SLIDE LOCK (LEFT)		2	610	CIRCLIP	S12	8
13	SUPPORT PIVOT SHAFT	Ø25 X 701	1	611	RUBBER FOOT		8
14	DROP PLATE PIN	Ø12 X 88	4	612	YELLOW RUBBER CAP	Ø16	2
15	CYLINDER PIN A (LOWER)	Ø20 X 112	1	613	HEX. BOLT	M10 X 20	2
16	CYLINDER PIN B (UPPER)	Ø20 X 70	1	614	SPRING WASHER	Ø10	2
17	SAFETY LOCK GUIDE		2	615	HEX. BOLT	M6 X 10	6
18	RAMP		1				
19	CAP		4	T	TOOL HOLDER (OPTIONAL)		2

APPENDIX

2 OPTIONAL EQUIPMENT

	<p>35-4040 MC10R Deluxe Wheel Clamp MC10R Deluxe Wheel Clamp. Self-locking clamp allows one person to load motorcycle on lifts. Comes with std. width rocker. (Fits 120 to 160 series tires)</p> <p>35-4041 Optional Narrow Rocker for. 90 to 110 tires</p>
	<p>35-9926 Crank Style Wheel Vice Can be used on front or rear tires</p>
	<p>35-6552 ATV Side Panels Complete Side Panel Set. Increases width from 29.5" to 59". Includes side panels (qt4) and ramps (qt 2)</p>
	<p>35-6557 Front/Rear Extension Panel Increases length by 24" (Sold each)</p>
	<p>37-8660 MC455 Fat Jack</p> <p>35-9872 MC460 Shop Dolly</p>
	<p>35-0321 Retractable Wheel Set Set of wheels for MC650. This accessory allows the lift to be easily moved.</p>
	<p>35-0318 Lift Extension Kit Adds 30" to your lift; and features easy bolt-on installation. Fits all flat deck style lifts.</p>
	<p>35-6770 Nosewheel Use with 35-0321 retractable wheels for easy moving of lift.</p>



K&L SUPPLY CO.

Setting The Industry Standard Since 1968

K&L SUPPLY CO., INC

1040 Richard Avenue, Santa Clara, CA, USA, 95050

TEL: 1-800-727-6767 FAX: 1-408-727-4842

www.klsupply.com