

# 18" MaxxAir Portable Evaporative Cooler Owner's Manual



**This Manual covers the EC18DVS MaxxAir Portable Evaporative Cooler.**



**File this owner's manual in a safe place for future reference.** It contains operating procedures – maintenance procedures – trouble shooting guide – replacement parts guide – order form – and contact information. **You will need this!**

# Warnings and Cautions

## Read before operating MaxxAir Portable Evaporative Cooler

### **ELECTRICAL**

- WARNING** Do not use a 3 prong to 2 prong adapter on the electrical power cord. Use 14 gauge extension cord only.
- WARNING** Do not remove the grounding lug from the electrical power cord plug.  
**Use only 3 prong, grounded receptacles.**
- WARNING** Disconnect the MaxxAir Portable Evaporative Cooler from your electrical power source before performing any service action.
- WARNING** Your MaxxAir unit must be plugged into a fused or circuit breaker protected 20 Amp, 120 Volt, 60 Hz circuit – unless specifically manufactured for another voltage / frequency configuration. See manufacturer’s label on cooler. A ground fault circuit interrupter protected circuit is strongly recommended.
- WARNING** Check your units electric power cord for insulation breaks, cracks or fraying. If any of these conditions are found DO NOT USE. See your distributor for immediate service replacement parts.
- WARNING** Some electric motors require periodic oiling. Check your model for oil fill holes. A couple drops of light oil per year normally will be sufficient. Heavy usage may require additional oil.
- WARNING** To reduce the risk of fire or electrical shock, DO NOT USE with any solid-state speed control device.
- WARNING** To reduce the risk of electrical shock or injury to persons, DO NOT USE cooler in a window.

### **WATER**

- WARNING** Do not connect your MaxxAir Portable Evaporative Cooler to any water source where water pressure exceeds 60 p.s.i. If your water source is above 60 p.s.i. you must use a pressure regulator (which can be found at your local hardware store).
- WARNING** **ALWAYS TURN-OFF WATER AT THE SOURCE EVERY NIGHT.**

# MaxxAir Portable Evaporative Cooler

## Table of Contents

- 1.0 Introduction
  - 1.1 Quick Start
  - 1.2 Operate unit for 2 weeks before adding Evap-O-Matic Tablets
- 2.0 How Evaporative Cooling Works
- 3.0 Unpacking your new MaxxAir unit
- 4.0 Set-up your MaxxAir unit
  - 4.1 Connecting the electrical supply
  - 4.2 Connecting the water supply
- 5.0 Operating procedures
  - 5.1 Filling the units reservoir with water
  - 5.2 Turn-on pump
  - 5.3 Turn-on Fan
- 6.0 Daily Operating procedures
  - 6.1 Turn-on pump
  - 6.2 Turn-on fan
  - 6.3 Turn-off unit
- 7.0 Maintenance
  - 7.1 Access inside of unit
  - 7.2 Removing the cooling media
  - 7.3 Daily maintenance
  - 7.4 Periodic maintenance
  - 7.5 MaxxAir Trouble Shooting Guide
- 8.0 Storage
- 9.0 Wiring Diagrams for 18" unit
- 10.0 Warranty

**File this owner's manual in a safe place for future reference.** It contains operating procedures – maintenance procedures – trouble shooting guide – replacement parts guide – order form – and contact information. **You will need this!**

# MaxxAir Portable Evaporative Cooler

## 1.0 Introduction

- Your MaxxAir was tested 3 ways. Your unit was *tested for* 1. Maximum air flow at operating static pressure. Only MaxxAir is *tested in operating conditions* with 2. *Water* and 3. *Electricity* before it is shipped.
- MaxxAir is *easy to operate* – needs only tap water and electricity to operate.
- MaxxAir is *easy to move* – roll your MaxxAir to the area you want to cool. MaxxAir comes standard with straight and swivel / lock casters which make moving your MaxxAir a breeze.

1.1 **Quick Start** – Your Quick Start Information is located inside the information packet shipped with your unit.

Look on the front of your MaxxAir packaging in a plastic sleeve.

1.2 Evap-O-Matic Tablet – Chemical Water Treatment. Operate your unit for 2 weeks – then, flush out old water – add clean water – then add ½ Chemical Water Treatment tablet. Note: Tablet makes water foam which can cause unit to spray water temporarily (for a day or two). You can order more tablets by calling 1.800.433.1626.

## 2.0 How Evaporative Cooling Works

Keeping in mind that regular fans only circulate same temperature air - same humidity – your MaxxAir portable evaporative cooler takes that same existing air, combines it with evaporating water (*which dramatically lowers the temperature*) immediately relieving hot, dry areas, similar to the conditions when a natural rain storm approaches, the temperature drops noticeably cooler, because the air is saturated with water. Because your air is now saturated with water it becomes noticeably cooler. In high humidity areas the temperature will not be as cool – however, the MaxxAir was engineered *efficient* to evaporate perspiration and sweat from employees to keep them cooler.

## 3.0 Unpacking your new MaxxAir unit

**Note: Carefully examine your MaxxAir shipping carton for damage before opening. If your carton is damaged – notify the shipper immediately!**

Your EC18” unit was shipped strapped a wooden pallet inside a cardboard box. First remove the straps then you may open the cardboard box. Your MaxxAir comes with a box of casters. Attach swivel casters to fan side of unit and straight casters to pad side. Use a 3/8” wrench to attach casters.

## 4.0 Set-up your MaxxAir unit.

Roll your MaxxAir unit to a level surface and lock the swivel casters to prevent accidental movement.

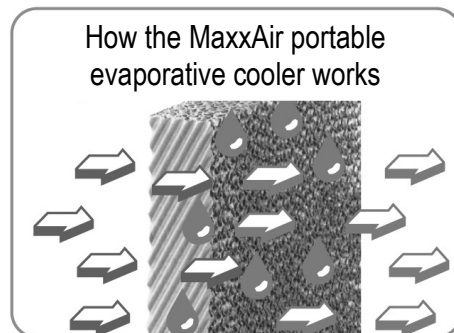

Hot, dryer air blowing through fan - about to mix with cooling media saturated with water.

Hot, dryer air - mixing with water molecules in the cooling media.

Moist, saturated air blowing out of fan - lowering the temperature up to 20° or more.

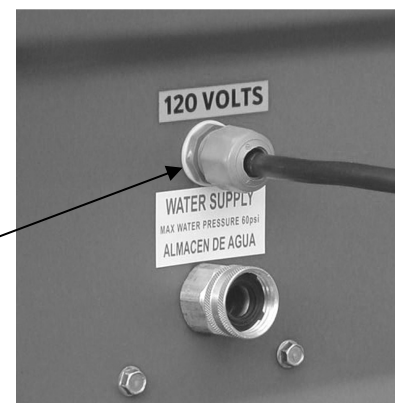

Electrical cord for 120V, 15Amp connection. Note: Standard ¾” water connection for utility water source under 60 p.s.i.

#### 4.1 Connecting the electrical supply

All MaxxAir models require regular 3 prongs, ground with 120 volt power supply. Plug electrical cord into receptacle. If using an extension cord be sure it is rated for at least 20 amps for the distance your cord is running. To be safe – make sure no other equipment, such as a radio or electrical equipment, is plugged into the same circuit. The MaxxAir should run smoothly on 20 amp, 120 volt, and 60 Hz circuit.

#### 4.2 Connecting the water supply

Connect standard water hose to female fitting on the right side of your MaxxAir (looking at the fan blade side). If your water pressure is above 60 pounds per square inch (p.s.i.) you must use a pressure regulator (which can be found at your local hardware store). **Note:** Do not connect to water source exceeding 60 p.s.i. – this can cause damage to your MaxxAir.

#### 5.0 Operating procedures

Back your MaxxAir unit up to a fresh air source such as an open door or window so the unit can pull in fresh air from the outside. Next, make sure you have a natural exhaust at the opposite end of the room, bay or building such as a window, door or bay door. This will ensure maximum efficiency from your unit. Finally make sure there are no obstructions between your MaxxAir and the people / area you need to cool.

#### 5.1 Filling the units reservoir with water

Once your water hose is connected, turn water on and fill the reservoir with water. Listen carefully. You can hear water filling the reservoir. Check your water connection – make sure there is no dripping. Once the reservoir is filled with water the float valve will automatically shut off the water source. When you no longer hear the water running – you know that the float valve is fully operational (the water turns off automatically) and you are now ready to turn on the water pump. **Warning! Do not run water pump without water in the reservoir.**

#### 5.2 Turn-on pump

To turn-on the water pump - flip the toggle switch for the water pump to on. Switch is located on front side of unit. **Warning! Do not run water pump without water in the reservoir.** The water pump will now begin pumping water to the top of the unit so that gravity will allow the water to run down the backside of unit inside and on the cooling pads. Once your MaxxAir cooling pads are saturated – then, you are ready to turn fan on high and begin to feel the cooling effect from your new MaxxAir. **Note:** After your cooling pads are broken in (typically takes 1 -2 weeks in operation) it will take less time to saturate pads for start-up. This is a good time to dump the old water – add ½ Evap-O-Matic Chemical Water Treatment tablet and refill with fresh water. (Simply remove a cooling pad to place tablet inside of water reservoir).

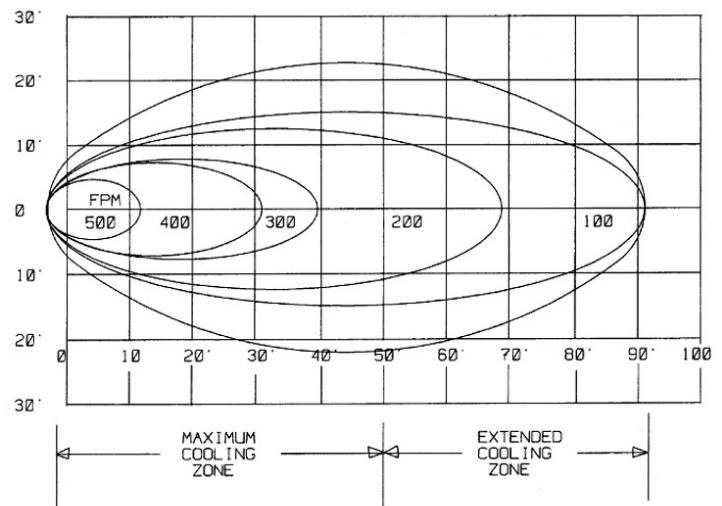

**NOTE: EXTENDED COOLING ZONE: 40' TO 50' FROM MAXXAIR UNIT. AIR MOVEMENT INCLUDES WARM AIR MIXING WITH COOLED AIR.**

#### 5.4 Turn-on Fan

Once your cooling pads are saturated with water – you may turn your MaxxAir unit on high. Now you can begin to feel the MaxxAir difference in temperature. After your MaxxAir has run for 5 minutes or so, visually inspect the pads – if water is dripping outside the unit – gently adjust pads at the bottom to stop water flowing outside the unit.

#### 6.0 Daily Operating procedures

##### 6.1 Turn-on water pump

Turn on water pump to unit – turn fan on low – let cooling pads get saturated – then turn fan on high for cooling. *You must determine what works best for you and your specific environment.*

##### 6.2 Turn fan on high

When you can see that the cooling pads are saturated with water – turn the fan on high and feel the cooler air coming from your MaxxAir unit. Adjust the fan speed for your comfort.

##### 6.3 Turn-off unit at end of day

15 minutes before closing for the day – (1.) Turn off water pump with toggle switch – (2.) Leave fan running – this action will shut-off water to the cooling pads while keeping the fan running. The fan will dry out the cooling pads. (3.) When the cooling pads are thoroughly dry – turn off fan. **Drying your cooling pads thoroughly - everyday will help prevent mold and mildew growth, plus it will prolong the life of your cooling pads.**

#### 7.0 Maintenance

##### 7.1 Access inside of unit

Turn-off water pump and let the fan continue to run until the cooling pads are thoroughly dry (about 10 – 15 minutes). Once your cooling pads are completely dry you may turn-off fan. Now unplug electricity to unit to avoid unnecessary shock. Next, using a 7/16” wrench – remove the two retaining bolts from the backside and topside (cooling pad side) of the unit. These two bolts hold the thick metal angle retaining bar and the cooling pads in place. Next, remove the angle retaining bar and set to side. Now you are ready to remove your unit’s cooling pads.

##### 7.2 Removing the cooling pads

**Before your start, make a note of the direction of the angle of the pads flutes (see side of pads). You must put pads back in correct order for your unit to function effectively. (Note: Install steep side 45° angle flute to the back of unit - see photo for verification.)**

Once the retaining angle bar is removed from the top of your MaxxAir unit, reach to the top of the dry cooling pad to the left and gently take hold of the top of the pad and gently pull down and back – this action will loosen the pad from the unit. Look at the direction of the angle of the pad flutes (*side of pads*). Remove the cooling pad and proceed to the next pad. Then, remove all cooling pads and gently set in a safe place. Note: this is a good time to take the cooling deck pads outside and run clean water over the pads to remove any accumulated dirt and debris. *Do not use high pressure hose* – this will damage pads and their ability to function effectively. Make sure the pads are thoroughly dry before placing back inside the unit.

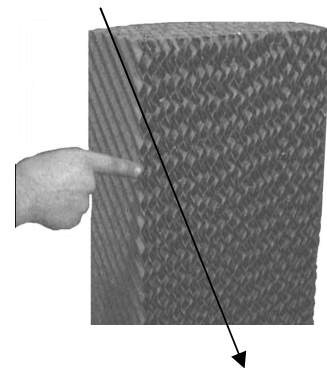

### 7.3 Daily maintenance

15 minutes before quitting time – turn off the water pump and let the fan run 10 – 15 minutes – to dry out the cooling pads before leaving. Inspect the cooling pads to make sure they are thoroughly dry (this action helps to reduce mold and mildew) when pads are completely dry then turn-off fan.

### 7.4 Periodic maintenance

Depending upon your environment and how often you operate your MaxxAir will depend on how dirty your water gets in the reservoir and how often you will need to clean it. If you begin to detect an *algae smell* coming from your unit – it’s time to flush your MaxxAir reservoir with fresh water. Refer to and follow the steps above in 7.2 and remove 1 of the cooling pads from the left side of the unit to gain access to your water reservoir. Take a small sponge and clean out your water reservoir with a light cleaner and wipe it down completely and let the unit dry. (You may want to use a wet / dry shop vacuum to clean out unit). When unit is clean add ½ Evap-O-Matic tablet to reservoir and replace your cooling pads (make sure flutes are facing correct direction – see photo) retaining bar and bolts and add fresh, clean water back to the units’ water reservoir. Note: You can order more Evap-O-Matic tablets by calling 1.800.433.1626.

**Warning! Do not run pump without water in the reservoir.** This action will burn up your MaxxAir’s water pump.

### 7.5 MaxxAir Trouble Shooting Guide

| Problem  | Cause   | Solution   |
|--|---|--|
| 1. Water on the Floor<br>A. Front of unit . . .<br><br>B. Back of unit | Damage to polyethylene housing. <u>Note:</u><br>Check for possible cracks in the blue polyethylene.<br><br>Excess water at top or bottom of pads.<br><br>Damage to blue polyethylene housing.<br><br>Leaking from bottom of pads. | Repair as necessary.<br><br>Very gently move pads slightly with your finger tips.<br><br>Search for leaks and repair as necessary.<br><br>Push bottom of cooling pads gently inside to stop leaking.   |
| 2. Found water on floor after overnight shut off.                      | Excessive water pressure.<br><br>Float valve maybe stuck in open position.  | Check your water pressure. Max water pressure is 60 p.s.i., by adding a water pressure regulator found at local hardware store.<br><br>Contaminants in water; drain cooler, sump and refill. If float remains stuck remove pads and examine float for debris or damage. Wash out debris and replace float. Continue. |
| 3. Foul odor from fan<br>A. New Unit . . .                             | New pad may have a temporary odor (this is normal) – you may be smelling the thermosetting resin – it will pass.  | Drain and refill several times in first week to remove thermosetting resin smell. Add Evap-O-Matic Tablet to reduce smell – and algae.   |

| <b>Problem</b> <i>(continued)</i>       | <b>Cause</b> <i>(continued)</i>   | <b>Solution</b> <i>(continued)</i>  |
|---|---|---|
| B. After normal use . . .               | Water quality – check your immediate environment.   | Water should be drained about once a month or sooner depending on your specific working environment – the water quality and conditions.   |
| 4. No water running over the pads . . . | Water supply off at main valve source.<br><br>Pump switch is off.<br><br>Water filter may be clogged. | Open water valve at supply. You may wish to keep this valve open at all times.<br><br>Turn pump switch on.<br><br>Remove the cooling pads see section 7.2. Open back of unit – open water filter – pull out filter screen and clean. Replace and try again. |
| 5. Scale build-up on cooling pads.      | Hard water with excessive mineral content.  | Use Evapo-O-Matic Tablet or add a Water Stabilizer at the discharge side of the pump.<br><br>Flush water from unit’s water reservoir more frequently. <i>See section 7.4.</i>   |

8.0 Storage

Remove pads as described above in 7.2 and rinse pads clean with fresh water. Dry cooling pads in sunlight. Drain water reservoir completely and wipe dry. Replace dry cooling pads in proper position. Replace top angle bar to hold pads in place. Store MaxxAir in dry, clean area and cover to prevent dust build up to have unit ready for the next hot season.

9.0 Wiring Diagrams for 18” unit

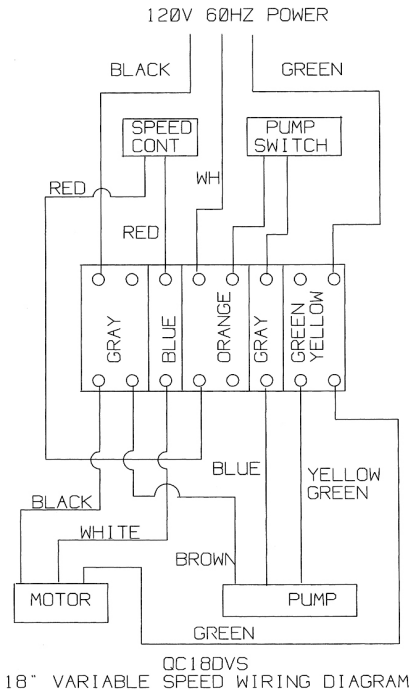



## 10.0 Warranty

### **LIMITED WARRANTY**

Ventamatic, Ltd. extends this warranty to the original retail purchaser of this fan against defects in materials and workmanship for a period of one (1) year from the date of purchase. There is no warranty for defects caused by abuse. Repairs or replacement parts supplied under this warranty are warranted only for the period of this warranty: that is one year from the date of the original retail purchase of this fan.

In the event of a defect or malfunction, we will replace or repair the defective part or component only and return the new repaired part to you freight prepaid. You must bear all other expenses incurred in obtaining repairs, including labor required for field repair or replacement and the cost of shipping the defective part or component to us. You must also bear the cost of repair to or replacement of any part or component and the shipping charges incurred for the repair or replacement and return to you of any part or component not covered by this warranty, including parts or components damaged by you.

The company reserves the right to demand and receive written evidence of the date of purchase before undertaking to perform its obligations under this warranty. You should, therefore, retain your sales slip and attach it to the warranty claim.

### **CALL OUR FACTORY FOR REPAIR OR REPLACEMENT PARTS**

In order to obtain the repair or replacement parts or components, you must call our factory at 1.800.433.1626. Customer service will provide detail instructions on how to proceed. **DO NOT** return to the retailer dealer.

There is no informal dispute settling mechanism available in the event of a controversy involving this warranty.

Any and all implied warranties which may exist terminate upon the termination of this written warranty, one year from the date of original retail purchase. Some states do not allow limitations on how long an implied warranty lasts, so these limitations may not apply to you.

Ventamatic, Ltd. is not liable to you for incidental or consequential damages arising out of a defect or malfunction of this fan or out of any alleged breach of this warranty. Some states do not allow the exclusion or limitation of incidental or consequential damages, so this limitation or exclusion may not apply to you.

This warranty gives you specific legal rights and you may also have other rights which may vary from state to state.

**Ventamatic, LTD.**  
100 WASHINGTON STREET  
MINERAL WELLS, TEXAS 76067  
TELEPHONE: 940.325.7887      TOLL FREE: 1.800.433.1626      FAX: 940.325.9311

Visit us online at: [www.bvc.com](http://www.bvc.com)