

The Stinger Folding Motorcycle Trailer



Owner's Manual

&

Warranty Information

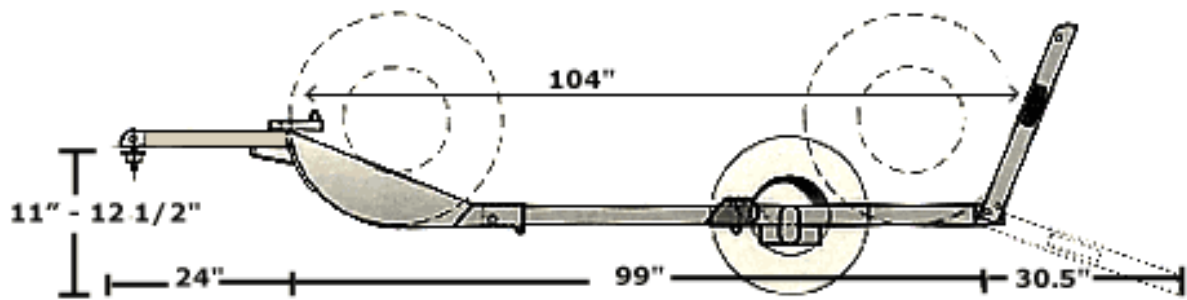
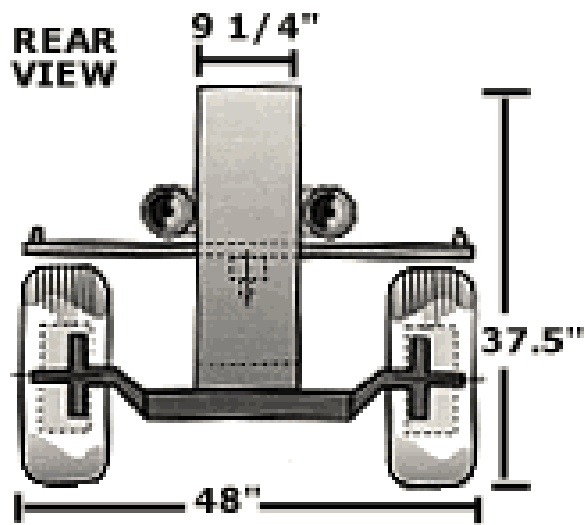

MAINTENANCE & FAB. INC.
PLEASE READ BEFORE USING YOUR
STINGER TRAILER

1. REMOVE ALL THREE (3) PINS BEFORE UNFOLDING TRAILER.
2. TRAILER MUST BE HOOKED TO VEHICLE BEFORE LOADING OR UNLOADING MOTORCYCLE.
3. BE CERTAIN THAT BOTH ½" PINS ARE INSTALLED IN TRAILER BEFORE LOADING MOTORCYCLE. BE SURE TO USE THE SNAP-OVER KEEPER PINS AT EACH LOCATION ALSO. 3/8" PIN HOLDS RAMP UPRIGHT AFTER LOADING.
4. PLACE ALUM TUBE UNDER REAR OF TRAILER BEFORE LOADING OR UNLOADING BIKE. SEE DIAGRAM.
5. READ INSTRUCTION LABEL LOCATED ON TRAILER TONGUE.
6. BEARINGS SHOULD BE GREASED EVERY 3000 MILES OR YEARLY.
7. TRAILER COMES WITH ELECTRICAL PLUG. OWNER NEEDS TO WIRE TOWING VEHICLE. (Some vehicles may require an inverter).
8. INFLATE TIRES EVENLY (35 LBS) AT ALL TIMES.
9. TRAILER MUST BE LEVEL ONCE MOUNTED. ADJUSTABLE BALL MOUNTS WORK WELL FOR THIS.
10. WHEN FOLDING AND UNFOLDING TRAILER, USE THE FRONT TIE-DOWN BAR AS A HANDLE. MAKE SURE HANDS ARE NOT PLACED AT THE FOLDING SECTIONS OF THE TRAILER WHEN FOLDING AND UNFOLDING TO AVOID PINCHING HANDS.
11. CHECK BOLTS ON TRAILER PERIODICALLY. ESPECIALLY FENDERS!
12. BE CAREFUL NOT TO PINCH ELECTRICAL CABLE WHEN FOLDING TRAILER.
13. BE SURE TO USE AT LEAST 4 RATCHET TYPE STRAPS TO TIE DOWN BIKE. !

- 14. IF EQUIPPED WITH RUNNING BOARDS, BE SURE TO REMOVE WHEN TRAVELING. THEY ARE MEANT FOR LOADING AND UNLOADING ONLY**
- 15. BE SURE TO READ CRADLE SETTINGS TO SET CHOCK FOR YOUR TIRE.**
- 16. THE SNAP PIN THAT IS IN THE BOTTOM HOLE OF THE HITCH PIN IS A SPARE, THE HOLE IS FOR A PADLOCK.**
- 17. THE GALVINIZED BUSHING THAT IS IN BETWEEN THE BRASS WASHERS IS A SPACER FOR THE HOLE IN THE BALL MOUNT.**

CRADLE SETTING INSTRUCTIONS

THE GUIDELINES PROVIDED ARE RECOMMENDATIONS ONLY. CRADLE SETTINGS MAY DIFFER DUE TO TIRE MANUFACTURING VARIATIONS SUCH AS TIRE LOT DIFFERENCES, TIRE CIRCUMFERENCE VARIATIONS BETWEEN LOTS OF SAME AND DIFFERENT BRAND TIRES. DUE TO THIS, THE STANDARD CRADLE SETTING PARAMETER SUPERSEDES ALL GUIDELINES PROVIDED.

STANDARD CRADLE SETTING PARAMETERS: THE CONDOR CRADLE MECHANISM IS DESIGNED SO THAT FOR EVERY TIRE/WHEEL SIZE WITHIN THE RANGES SPECIFIED A MINIMUM OF 2 CRADLE SETTINGS ARE SUITABLE. THE OPTIMUM SETTING FOR A SPECIFIC TIRE WOULD BE THE SETTING THAT ALLOWS THE CRADLE TO TILT AS FAR FORWARD AS POSSIBLE WITHOUT MAKING CONTACT WITH THE UNIT ITSELF (SC2000) OR THE UNIT'S MOUNTING SURFACE OR THE GROUND (PS1500). THE 2ND OPTIMUM SETTING WOULD BE THE SETTING FORWARD FROM THE OPTIMUM SETTING WHICH IS AWAY FROM THE ENTRY DIRECTIONS OF THE UNIT. IF LESS RETENTION IS DESIRED AT ANY TIME DUE TO TOO MUCH STICKING, THE 2ND OPTIMUM SETTING MAY BE MORE SUITABLE.

RACING TIRE SETTINGS FOR GP OR LOW DUROMETER TIRE COMPOUNDS WOULD BE THE 5TH AND 6TH (PS1500). THIS ALLOWS FOR THE LEAST AMOUNT OF STICKING WHEN USING THE PS1500 FREE STANDING.

FOR SPORTBIKES WITH LOW HANGING CHIN FAIRINGS OR BIKES WITH VERY LOW FENDERS AND/OR COWLINGS, THE CRADLE MAY BE TURNED 180 DEGREES FOR ADDITIONAL CLEARANCE, SO AS NOT TO MAKE CONTACT.

CRADLE SETTING GUIDELINES: DUE TO THE NUMEROUS TIRE WHEEL COMBINATIONS AVAILABLE, THESE GUIDELINES WILL PROVIDE IN GENERAL MANOR THE PLACEMENTS OF THE MOST COMMON SIZES SEEN ON THE MARKET. THESE SETTINGS ARE RECOMMENDATION GUIDELINES, THEY ARE NOT SPECIFIC GUIDELINES AND THAT THE STANDARD CRADLE SETTING PARAMETERS SHOULD BE FOLLOWED TO CUSTOMIZE THE SETTING FOR YOUR PARTICULAR VEHICLE.

Front/Rear	Width-Diam	1st Opt. Setting	2nd Opt. Setting
Front	80, 90 - 21"	1	2
Front	100, 120 - 21"	1	1
Front	100 - 18"	2	3
Front	100 - 19"	2	2
	120 - 17"	4	5
	130 - 16"	2	3
	140 - 17"	1	2
	150 - 17"	1	1
Rear	150+	1	1

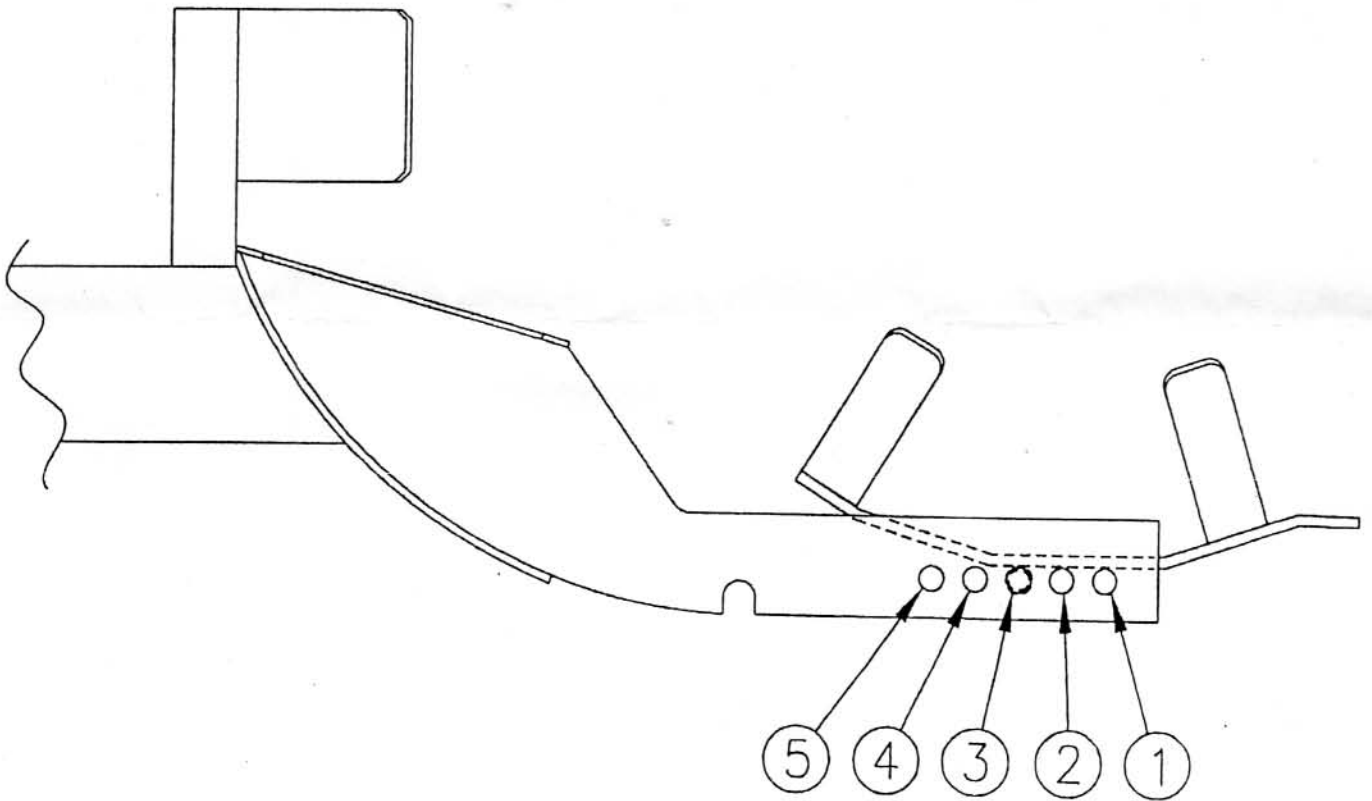

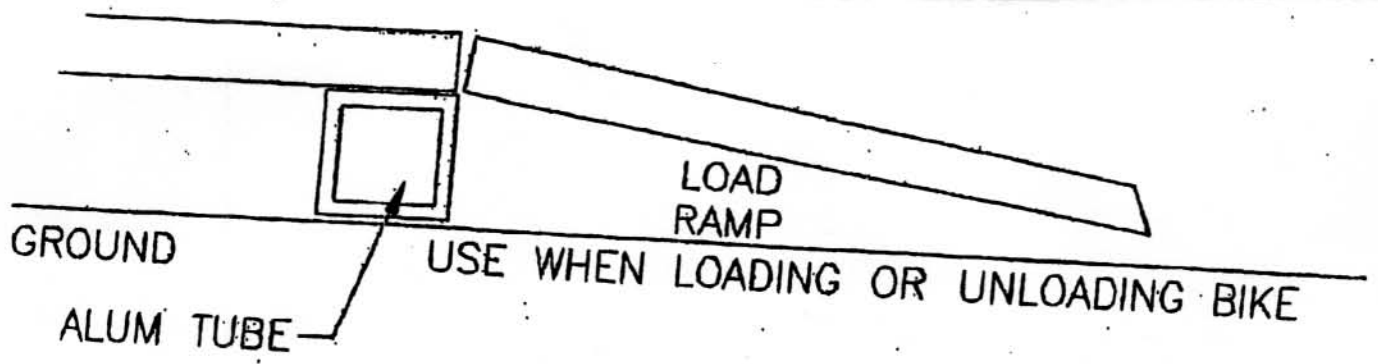
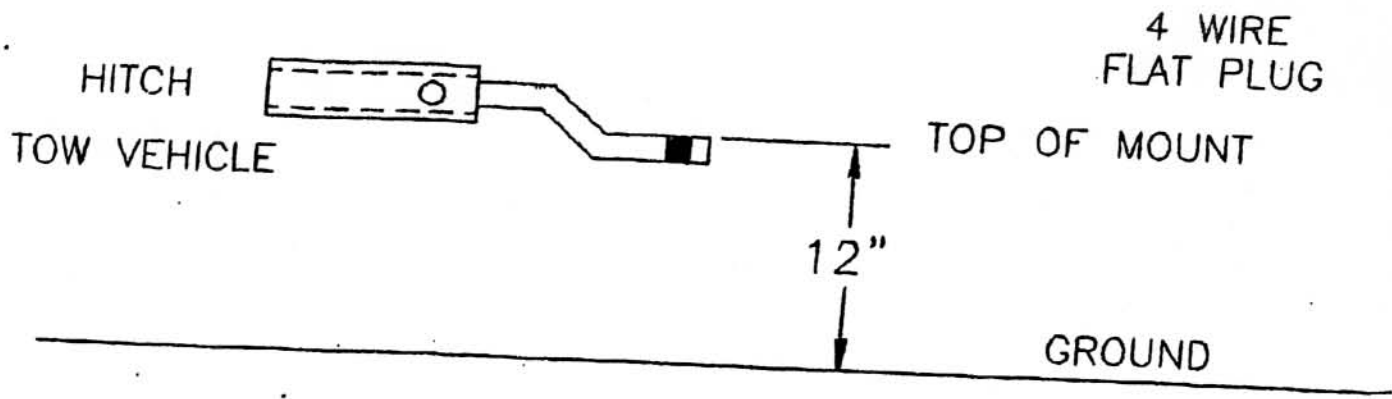

MAINTENANCE & FAB, INC.

STINGER TRAILER LIMITED WARRANTY

Maintenance & Fab, Inc. warrants to the original retail purchaser that the Stinger Trailer is free from defects in material and workmanship and agrees to repair or replace, at Maintenance & Fab., Inc.'s discretion, any defective parts free of charge within this time period from the date of purchase:

- **Two years, if the Product is used for personal use only.**

This warranty is not transferable and does not cover damage resulting from defects other than in material or workmanship, or damage caused by unreasonable use, including the failure to provide reasonable and necessary maintenance. Also, the warranty obligations do not apply to conditions resulting from misuse, alteration or accident. In addition, this warranty does not cover replacement of non-defective parts (such as electrical wires & plugs) that may wear and need to be replaced with reasonable use within the warranty period or which may require replacement in connection with normal maintenance.

DAMAGES NOT COVERED UNDER WARRANTY DUE TO MISUSE

- **Traveling more than the designated 70 mph maximum that the tires are rated at.**
- **Not following instruction labels located on trailer and instruction sheet provided to consumer at time of purchase.**

HOW TO OBTAIN WARRANTY SERVICE

Warranty service can be obtained from Maintenance & Fab., Inc. (1-800-701-5501). Shipping charges for parts sent back to the repair center are the responsibility of the purchaser depending on the type of defect to the product.